

Bridgelux® SMD 3838 RGBW 3V

Product Data Sheet DS1402

Introduction

SMD 3838 RGBW

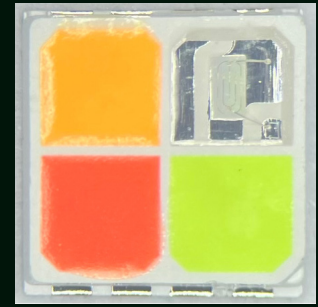

The Bridgelux SMD 3838 low power LED is cold-color targeted, which ensures that the LEDs fall within their specified color bin at the typical application conditions of 25°C. The SMD 3838 is ideal as a drop-in replacement for emitters with an industry standard 3.8mm x 3.8mm footprint.

Features

- Industry-standard 3838 footprint
- RoHS compliant and lead free
- RGBW 4 in 1
- RGB is for decorative lighting
- RGBW color tunable along BBC to mix 2200K-6500K with high CRI90 or CRI95, and the white CCT meets IEC62471 Risk Group 0

Benefits

- Lower operating and manufacturing cost
- Ease of design and rapid go-to-market
- Compliant with environmental standards
- Design flexibility

Contents

Product Feature Map	2
Product Nomenclature	2
Product Test Conditions	2
Product Selection Guide	3
Performance at Commonly Used Drive Currents	6
Electrical and Thermal Characteristics	7
Absolute Maximum Ratings	8
Product Bin Definitions	9
Performance Curves	12
Typical Radiation Pattern	15
Typical Color Spectrum	16
Mechanical Dimensions	17
Reliability	18
Reflowing Characteristics	19
Design Resources	20
Precautions	20
Disclaimers	20
About Bridgelux	21

Product Feature Map

Bridgelux SMD LED products come in industry standard package sizes . These LEDs are optimized for cost and performance, helping to ensure highly competitive system lumen per dollar performance while addressing the stringent efficacy and reliability standards required for modern lighting applications.

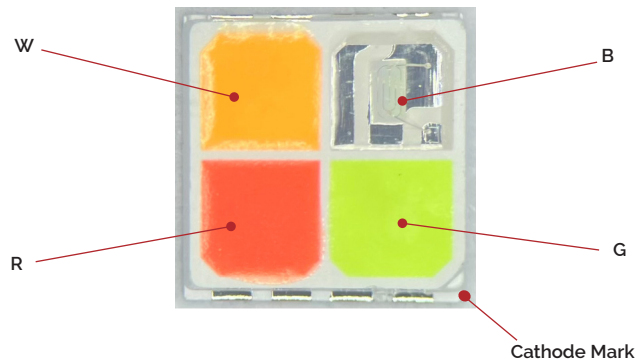

Product Nomenclature

The part number designation for Bridgelux SMD 3838 RGBW is explained as follows:

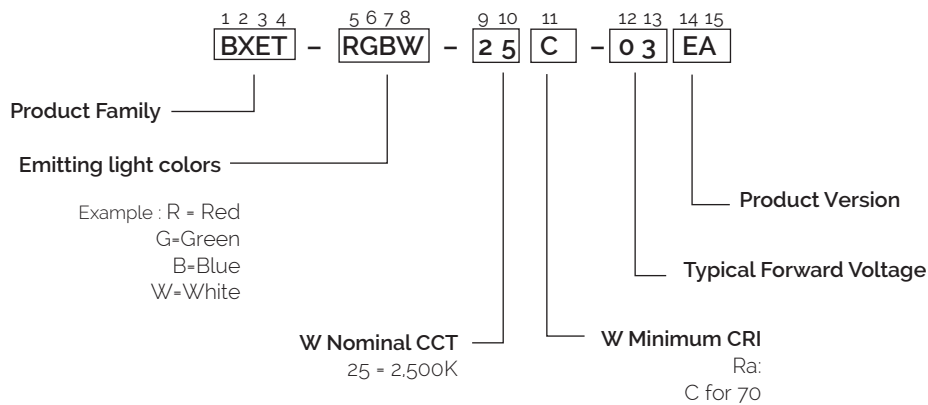

Product Test Conditions

Bridgelux SMD 3838 LEDs are tested and binned with a 10ms pulse of 120mA at T_j (junction temperature)= T_{sp} (solder point temperature) =25°C. Luminous flux , color and forward voltage are binned at $T_j=T_{sp}=25^\circ\text{C}$.

Product Selection Guide

The following product configurations are available:

Table 1: Selection Guide, RGB Pulsed Measurement Data at 120mA ($T_j=T_{sp}=25^{\circ}\text{C}$)

Part Number ³	Color	Nominal Drive Current (mA)	Forward Voltage ^{1,2} (V)			Typical Pulsed Flux ^{1,2} (lm)	Dominant Wavelength ^{1,2} (nm)
			Min	Typical	Max		
BXET-RGBW-25C-03EA	Red	120	2.8	3.0	3.2	14.5	618.0
	Green	120	2.8	3.0	3.2	75.0	535.2
	Blue	120	2.8	3.0	3.2	8.4	458.0

Table 2: Selection Guide, W pulsed Measurement Data at 120mA ($T_j=T_{sp}=25^{\circ}\text{C}$)

Part Number	Color	Nominal CCT (K)	CRI	Nominal Drive Current (mA)	Forward Voltage ^{1,2} (V)			Typical Pulsed Flux ^{1,2} (lm)
					Min	Typical	Max	
BXET-RGBW-25C-03EA	White	2500	70	120	2.8	3.0	3.2	57.0

Table 3: Selection Guide, RGB pulsed Measurement Data at 120mA ($T_j=T_{sp}=85^{\circ}\text{C}$)

Part Number	Color	Nominal Drive Current (mA)	Forward Voltage ^{1,2} (V)			Typical Pulsed Flux ^{1,2} (lm)	Dominant Wavelength ^{1,2} (nm)
			Min	Typical	Max		
BXET-RGBW-25C-03EA	Red	120	2.7	2.9	3.1	13.4	617.0
	Green	120	2.7	2.9	3.1	63.1	535.2
	Blue	120	2.7	2.9	3.1	8.6	460.0

Table 4: Selection Guide, W pulsed Measurement Data at 120mA ($T_j=T_{sp}=85^{\circ}\text{C}$)

Part Number	Color	Nominal CCT (K)	CRI	Nominal Drive Current (mA)	Forward Voltage ^{1,2} (V)			Typical Pulsed Flux ^{1,2} (lm)
					Min	Typical	Max	
BXET-RGBW-25C-03EA	White	2500	70	120	2.7	2.9	3.1	52.0

Notes for Tables 1, 2, 3 and 4:

1. Products tested under pulsed condition (10ms pulse width) at nominal drive current.
2. Bridgelux maintains a $\pm 7.5\%$ tolerance on luminous flux measurements, $\pm 0.1\text{V}$ tolerance on forward voltage measurements, and $\pm 1\text{nm}$ tolerance on dominant wavelength measurements for SMD 3838.
3. Refer to Tables 12, 13 and 14 for Bridgelux SMD 3838 flux Binning and Forward Voltage Binning and Dominant Wavelength Binning information.

Product Selection Guide

Table 5: Selection Guide, Tunable White with CRI90 ($T_{sp} = 25^{\circ}\text{C}$)

Power	CCT	W ratio	R ratio	G ratio	B ratio	W Drive Current (mA)	R Drive Current (mA)	G Drive Current (mA)	B Drive Current (mA)	CIE-X	CIE-Y	CRI	Rg	Power (w)	Flux (lm)	Efficacy (lm/w)
0.5W	1800	42.11%	55.08%	2.82%	0.00%	63.2	82.6	4.2	0.0	0.5336	0.4017	92.1	62.4	0.429	45.1	105.2
	2200	51.50%	41.80%	6.43%	0.26%	77.3	62.7	9.6	0.4	0.5023	0.4175	93.7	58.5	0.426	53.1	124.5
	2700	56.20%	30.34%	11.13%	2.33%	84.3	45.5	16.7	3.5	0.4593	0.4128	94.0	57.2	0.423	59.3	140.1
	3000	57.12%	24.92%	14.05%	3.91%	85.7	37.4	21.1	5.9	0.4355	0.4063	94.0	56.4	0.421	62.1	147.5
	3500	56.95%	19.77%	17.18%	6.09%	85.4	29.7	25.8	9.1	0.4097	0.3954	93.7	55.1	0.421	64.4	153.2
	4000	55.08%	15.60%	20.75%	8.57%	82.6	23.4	31.1	12.9	0.3845	0.3837	93.2	54.2	0.419	66.4	158.5
	5000	50.00%	10.94%	25.86%	13.20%	75.0	16.4	38.8	19.8	0.3472	0.3599	92.3	54.0	0.418	67.5	161.2
	5700	48.68%	8.31%	27.22%	15.79%	73.0	12.5	40.8	23.7	0.3316	0.3462	92.2	52.1	0.419	67.6	161.6
	6500	45.49%	6.54%	29.44%	18.53%	68.2	9.8	44.2	27.8	0.3150	0.3327	91.7	51.8	0.419	67.4	161.1

Table 6: Selection Guide, Tunable White with CRI90 ($T_{sp} = 85^{\circ}\text{C}$)

Power	CCT	W ratio	R ratio	G ratio	B ratio	W Drive Current (mA)	R Drive Current (mA)	G Drive Current (mA)	B Drive Current (mA)	CIE-X	CIE-Y	CRI	Rg	Power (w)	Flux (lm)	Efficacy (lm/w)
0.5W	1800	42.11%	55.08%	2.82%	0.00%	63.2	82.6	4.2	0.0	0.5325	0.4000	91.2	58.9	0.419	41.4	98.8
	2200	51.50%	41.80%	6.43%	0.26%	77.3	62.7	9.6	0.4	0.5013	0.4151	92.7	56.1	0.417	48.5	116.4
	2700	56.20%	30.34%	11.13%	2.33%	84.3	45.5	16.7	3.5	0.4577	0.4099	93.1	56.1	0.413	54.0	130.6
	3000	57.12%	24.92%	14.05%	3.91%	85.7	37.4	21.1	5.9	0.4338	0.4030	93.2	56.2	0.412	56.5	137.3
	3500	56.95%	19.77%	17.18%	6.09%	85.4	29.7	25.8	9.1	0.4075	0.3918	93.1	55.8	0.411	58.6	142.5
	4000	55.08%	15.60%	20.75%	8.57%	82.6	23.4	31.1	12.9	0.3819	0.3796	92.9	56.2	0.409	60.3	147.2
	5000	50.00%	10.94%	25.86%	13.20%	75.0	16.4	38.8	19.8	0.3447	0.3554	92.9	56.6	0.409	61.1	149.3
	5700	48.68%	8.31%	27.22%	15.79%	73.0	12.5	40.8	23.7	0.3289	0.3417	92.6	56.9	0.409	61.2	149.6
	6500	45.49%	6.54%	29.44%	18.53%	68.2	9.8	44.2	27.8	0.3123	0.3282	92.1	57.1	0.409	60.9	149.0

Product Selection Guide

Table 7: Selection Guide, Tunable White with CRI95 ($T_{sp} = 25^{\circ}\text{C}$)

Power	CCT	W ratio	R ratio	G ratio	B ratio	W Drive Current (mA)	R Drive Current (mA)	G Drive Current (mA)	B Drive Current (mA)	CIE-X	CIE-Y	CRI	Rg	Power (w)	Flux (lm)	Efficacy (lm/w)
0.5W	2200	45.86%	46.13%	7.71%	0.30%	68.8	69.2	11.6	0.5	0.5019	0.4173	94.8	72.1	0.427	51.3	120.2
	2700	50.38%	34.89%	12.44%	2.29%	75.6	52.3	18.7	3.4	0.4590	0.4130	96.4	72.1	0.422	57.6	136.6
	3000	50.38%	30.38%	15.45%	3.80%	75.6	45.6	23.2	5.7	0.4355	0.4066	96.8	74.1	0.421	60.0	142.7
	3500	50.38%	25.08%	18.61%	5.94%	75.6	37.6	27.9	8.9	0.4091	0.3959	96.7	72.9	0.419	62.5	149.2
	4000	47.37%	21.99%	22.37%	8.27%	71.1	33.0	33.6	12.4	0.3837	0.3842	96.7	76.8	0.418	63.8	152.8
	5000	42.48%	17.67%	27.11%	12.74%	63.7	26.5	40.7	19.1	0.3467	0.3597	95.9	80.0	0.416	64.8	155.7
	5700	38.35%	17.44%	29.17%	15.04%	57.5	26.2	43.8	22.6	0.3302	0.3460	96.8	89.0	0.415	63.9	154.0
	6500	34.96%	16.20%	31.24%	17.59%	52.4	24.3	46.9	26.4	0.3139	0.3328	96.5	91.8	0.414	63.8	154.1

Table 8: Selection Guide, Tunable White with CRI95 ($T_{sp} = 85^{\circ}\text{C}$)

Power	CCT	W ratio	R ratio	G ratio	B ratio	W Drive Current (mA)	R Drive Current (mA)	G Drive Current (mA)	B Drive Current (mA)	CIE-X	CIE-Y	CRI	Rg	Power (w)	Flux (lm)	Efficacy (lm/w)
0.5W	2200	45.86%	46.13%	7.71%	0.30%	68.8	69.2	11.6	0.5	0.5010	0.4150	94.5	69.2	0.417	46.9	112.4
	2700	50.38%	34.89%	12.44%	2.29%	75.6	52.3	18.7	3.4	0.4578	0.4099	95.5	70.7	0.413	52.5	127.3
	3000	50.38%	30.38%	15.45%	3.80%	75.6	45.6	23.2	5.7	0.4339	0.4032	95.9	73.5	0.411	54.6	132.8
	3500	50.38%	25.08%	18.61%	5.94%	75.6	37.6	27.9	8.9	0.4074	0.3919	95.8	74.3	0.409	56.8	138.7
	4000	47.37%	21.99%	22.37%	8.27%	71.1	33.0	33.6	12.4	0.3818	0.3799	96.0	78.7	0.408	57.9	141.7
	5000	42.48%	17.67%	27.11%	12.74%	63.7	26.5	40.7	19.1	0.3448	0.3553	96.0	82.7	0.407	58.7	144.3
	5700	38.35%	17.44%	29.17%	15.04%	57.5	26.2	43.8	22.6	0.3288	0.3416	95.8	93.2	0.406	57.8	142.5
	6500	34.96%	16.20%	31.24%	17.59%	52.4	24.3	46.9	26.4	0.3122	0.3284	95.5	95.8	0.405	57.7	142.6

Performance at Commonly Used Drive Currents

SMD 3838 RGBW specifications at nominal drive current are shown in Tables 1 & 2. SMD 3838 RGBW may also be driven at other drive currents dependent on specific application design requirements. The performance at any drive current can be derived from the current vs. voltage characteristics shown in Figure 2 and the relative luminous flux vs. current characteristics shown in Figure 3. The performance at commonly used drive currents is summarized in Table 9.

Table 9: Performance at Commonly Used Drive Currents

Part Number	Color	Drive Current ¹ (mA)	Typical Voltage T _{sp} =25°C (V)	Typical Pulsed Flux ² T _{sp} =25°C (lm)	Typical Pulsed Flux ² T _{sp} =85°C (lm)
BXET-RGBW-25C-03EA	Red	30	2.7	41	3.9
		60	2.8	7.9	7.3
		90	2.9	11.3	10.5
		120	3.0	14.5	13.4
		160	3.1	18.4	16.9
	Green	30	2.7	20.4	17.9
		60	2.8	39.6	34.3
		90	2.9	57.6	49.2
		120	3.0	75.0	63.1
		160	3.1	96.1	79.5
	Blue	30	2.7	2.5	2.6
		60	2.8	4.6	4.8
		90	2.9	6.6	6.7
		120	3.0	8.4	8.6
		160	3.1	10.6	10.7
	White	30	2.7	15.5	14.5
		60	2.8	30.1	27.8
		90	2.9	43.8	40.2
		120	3.0	57.0	52.0
		160	3.1	73.2	66.2

Notes for Table 9:

1. Alternate drive currents in Table 9 are provided for reference only and are not a guarantee of performance.
2. Bridgelux maintains a ± 7.5% tolerance on flux measurements.
3. Typical pulsed performance values are provided as reference only and are not a guarantee of performance.

Electrical and Thermal Characteristics

Table 10: Electrical and Thermal Characteristics

Part Number	Color	Drive Current (mA)	Forward Voltage ^{1,2} (V)			Typical Temperature Coefficient of Forward Voltage ³ $\Delta V_f / \Delta T$ (mV/°C)	Typical Thermal Resistance Junction to Solder Point ⁴ R_{j-sp} (°C/W)
			Minimum	Typical	Maximum		
BXET-RGBW-25C-03EA	Red	120	2.8	3.0	3.2	-1.1	31.0
	Green	120	2.8	3.0	3.2	-1.0	24.1
	Blue	120	2.8	3.0	3.2	-1.0	23.4
	White	120	2.8	3.0	3.2	-1.0	28.2

Notes for Table 10:

1. Products tested under pulsed condition (10ms pulse width) where $T_{sp} = 25^\circ\text{C}$.
2. Bridgelux maintains a tolerance of $\pm 0.1\text{V}$ on forward voltage measurements.
3. Products measured between 25°C and 85°C under pulsed condition (10ms pulse width).
4. Thermal resistance value was calculated using total electrical input power; optical power was not subtracted from input power.

Absolute Maximum Ratings

Table 11: Maximum Ratings

Parameter	Maximum Rating			
LED Junction Temperature (T_j)	125°C			
Storage Temperature	-40°C to +105°C			
Operating Solder Point Temperature (T_{sp})	-40°C to +105°C			
Soldering Temperature	260°C or lower for a maximum of 10 seconds			
	R	G	B	W
DC Forward Current(single color light)	160mA	160mA	160mA	160mA
Peak Pulsed Forward Current ¹	200mA	200mA	200mA	200mA
Maximum Power	1W			
Maximum Reverse Voltage ²	-5V			
Moisture Sensitivity Rating	MSL 3			
Electrostatic Discharge	2kV HBM. JEDEC-JS-001-HBM and JEDEC-JS-001-2012			

Notes for Table 11:

1. Bridgelux recommends a maximum duty cycle of 10% and pulse width of 10 ms when operating SMD 3838 at maximum peak pulsed current specified. Maximum peak pulsed currents indicate values where SMD 3838 can be driven without catastrophic failures.
2. Light emitting diodes are not designed to be driven in reverse voltage and will not produce light under this condition. Maximum rating provided for reference only.

Product Bin Definitions

Table 12 lists the standard photometric luminous flux bins for SMD 3838 RGBW. Although several bins are outlined, product availability in a particular bin varies by production run and by product performance.

Table 12: Luminous Flux Bin Definitions at 120mA, $T_{sp}=25^{\circ}\text{C}$

Color	Bin Code	Luminous Flux ¹		Unit	Condition
		Minimum	Maximum		
R	R3	13	20	lm	$I_F=120\text{mA}$
G	G8	66	84		
B	B2	7	13		
W	W7	50	66		

Note for Table 12:

1. Bridgelux maintains a tolerance of $\pm 7.5\%$ on luminous flux measurements.

Table 13: Forward Voltage Bin Definitions at 120mA, $T_{sp}=25^{\circ}\text{C}$

Color	Bin Code	Forward Voltage ¹		Unit	Condition
		Minimum	Maximum		
R/G/B/W	A1	2.8	3.2	V	$I_F=120\text{mA}$

Note for Table 13:

1. Bridgelux maintains a tolerance of $\pm 0.1\text{V}$ on forward voltage measurements.

Table 14: Dominant Wavelength Bin Definitions at 120mA, $T_{sp}=25^{\circ}\text{C}$

Color	Bin Code	Dominant Wavelength ¹		Unit	Condition
		Minimum	Maximum		
B	P	455	460	nm	$I_F=120\text{mA}$
	Q	460	465		

Note for Table 14:

1. Bridgelux maintains a tolerance of $\pm 1\text{nm}$ on dominant wavelength measurements.

Product Bin Definitions

Table 15: RGW MacAdam Ellipse Color Bin Definitions ($T_{sp}=25^{\circ}\text{C}$)

Color	Color Space	Center Point		Major Axis	Minor Axis	Ellipse Rotation Angle	Color Bin
		X	Y				
R	6 Step	0.6769	0.3139	0.01854	0.00828	5.0	6
G	6 Step	0.2488	0.6094	0.01854	0.00828	73.0	6
W	3 Step	0.4870	0.4320	0.00810	0.00420	53.7	3
	6 Step			0.01620	0.00840	53.7	3/A/B/C/D

Notes for Table 15:

1. Color binning at $T_{sp}=25^{\circ}\text{C}$ unless otherwise specified.
2. Bridgelux maintains a tolerance of ± 0.007 on x and y color coordinates in the CIE 1931 color space .

Product Bin Definitions

Figure 1: C.I.E. 1931 Chromaticity Diagram (Color Bin Structure, $T_{sp} = 25^{\circ}\text{C}$)

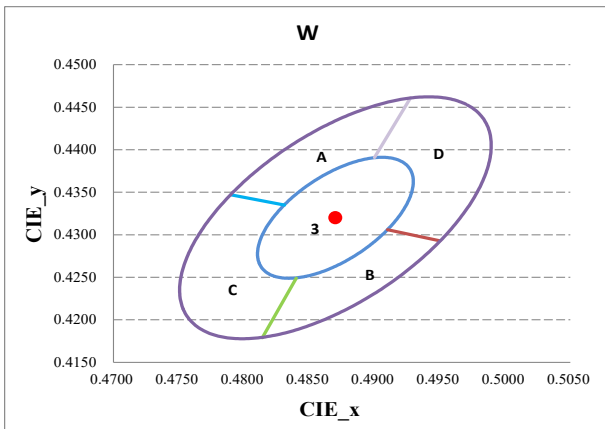
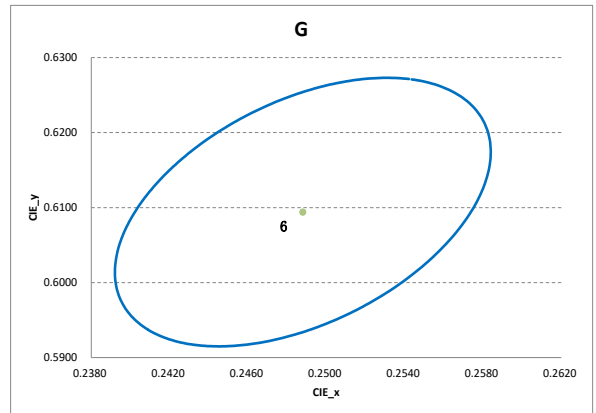
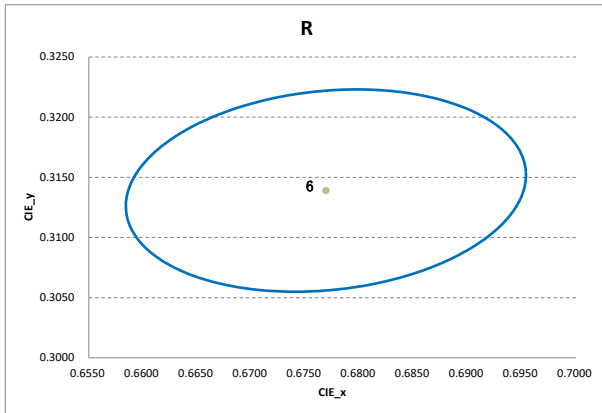

Performance Curves

Figure 2: Drive Current vs. Voltage ($T_{sp}=25^{\circ}\text{C}$)

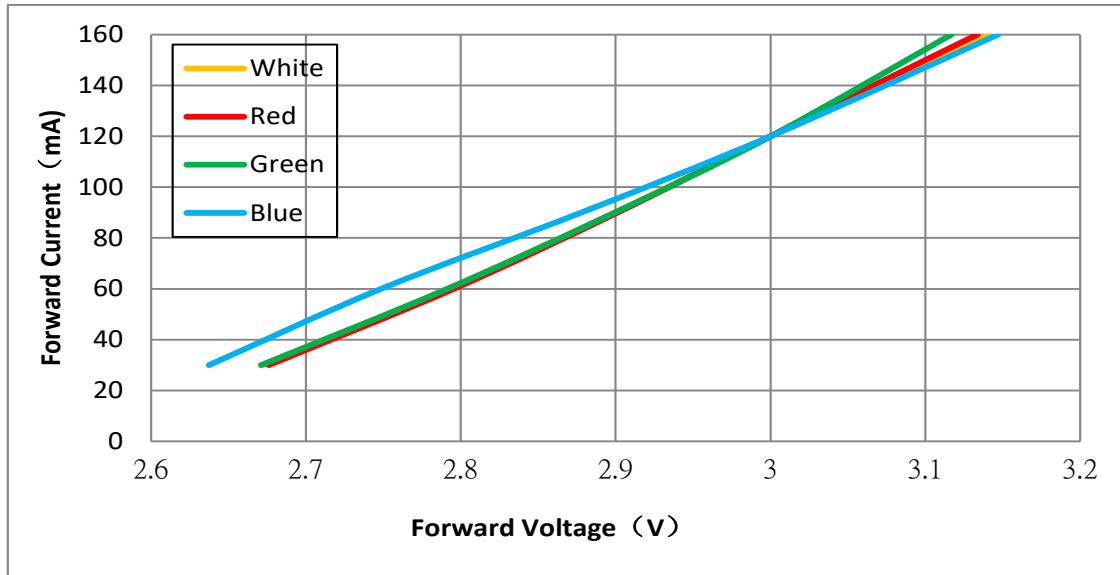
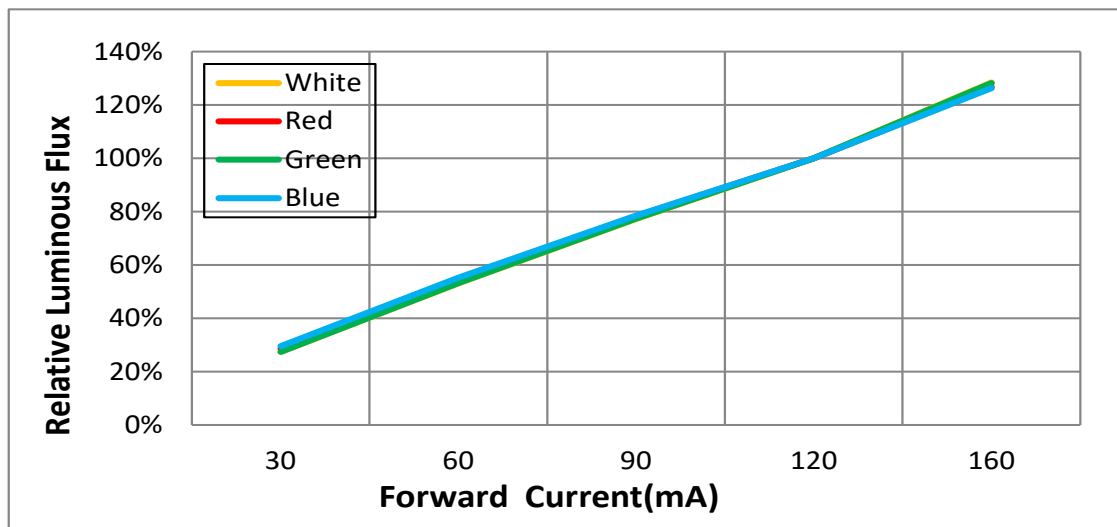

Figure 3: Typical Relative Luminous Flux vs. Drive Current ($T_{sp}=25^{\circ}\text{C}$)



Note for Figure 3:

1. Pulse width modulation (PWM) is recommended for dimming effects.

Performance Curves

Figure 4: Typical Relative Flux vs. Solder Point Temperature_120mA

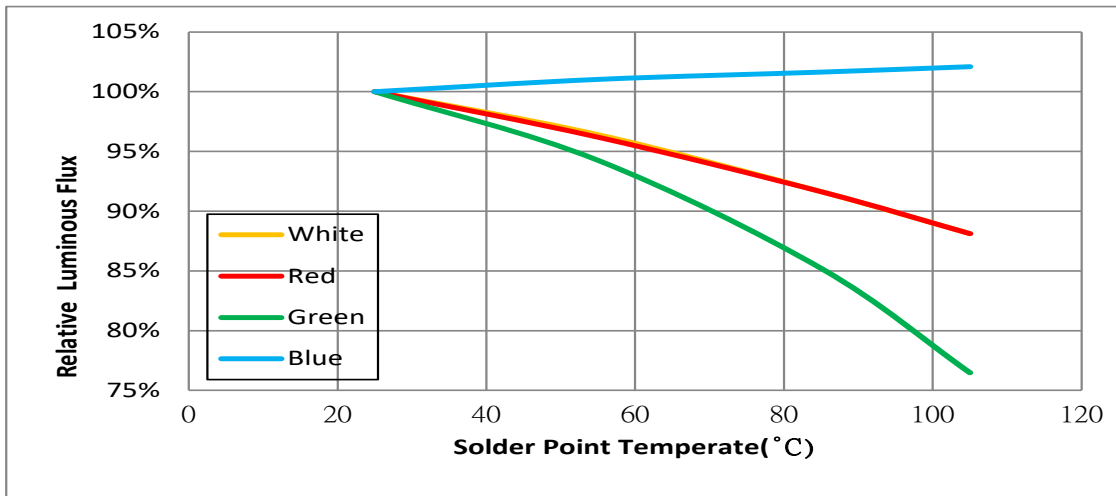
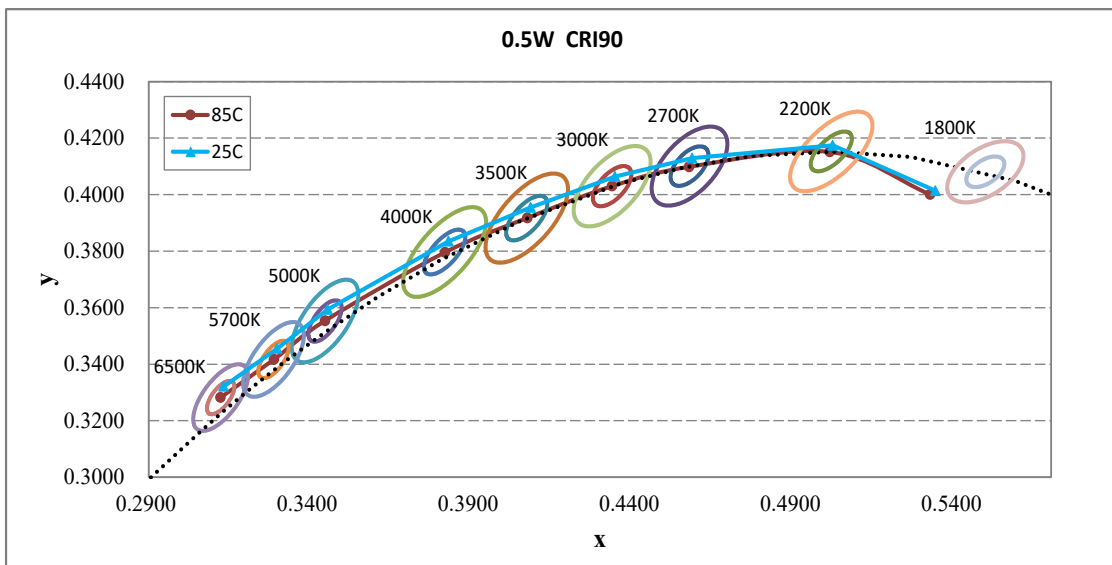
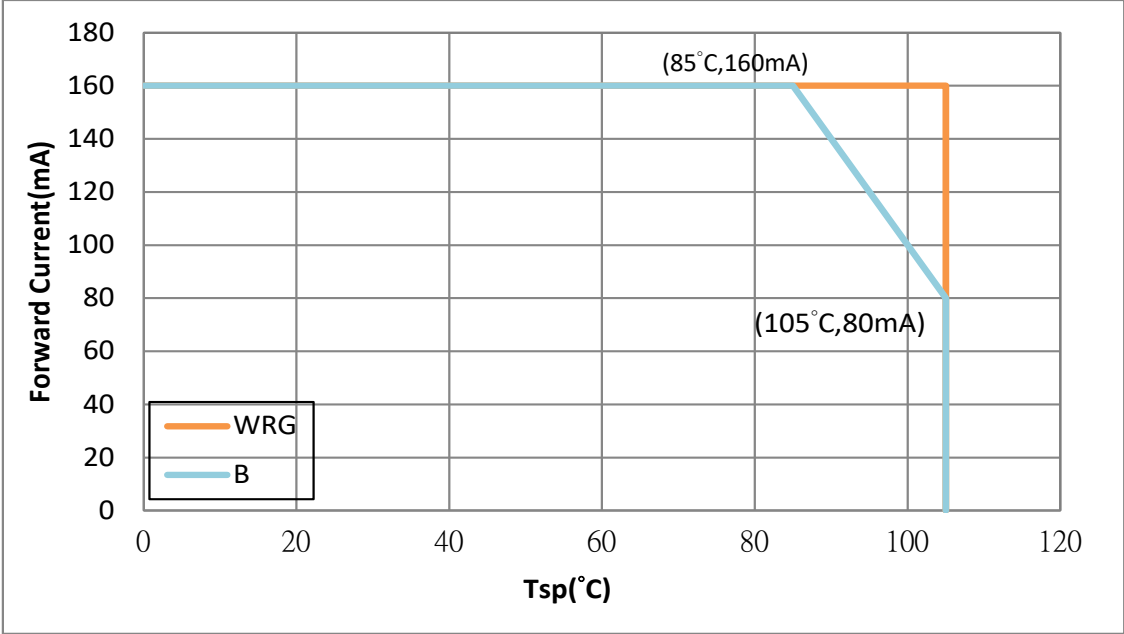

Figure 5: Chromaticity Coordinate Group(Color Targeted at $T_{sp} = 25^{\circ}\text{C}$ & 85°C)



Performance Curves

Figure 6: Drive Current vs Solder Point Temperature



Typical Radiation Pattern

Figure 7: Typical Spatial Radiation Pattern at 120mA, $T_{sp}=25^{\circ}\text{C}$

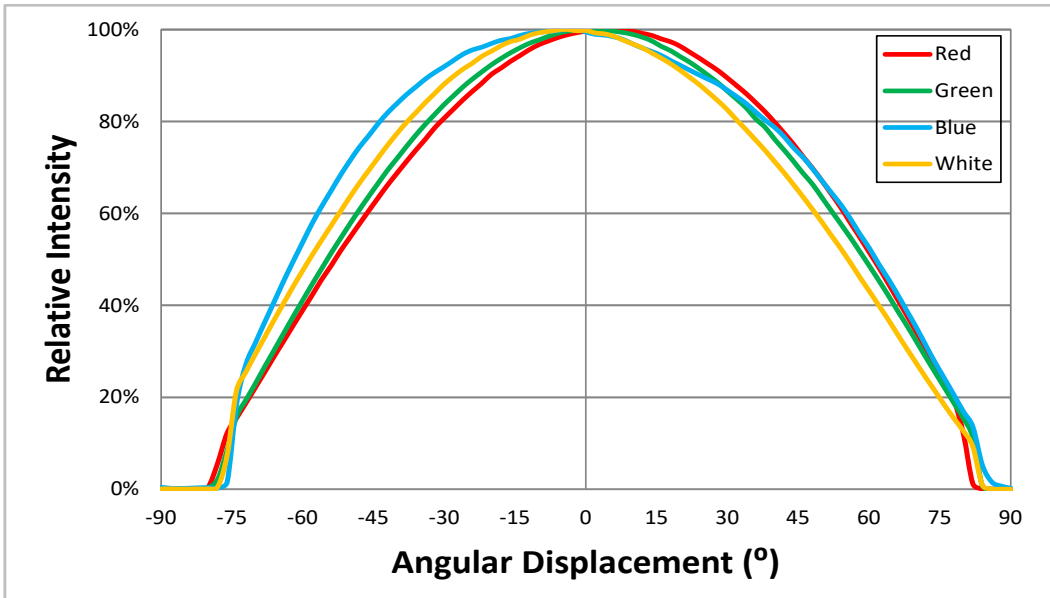

Notes for Figure 7:

1. WRG typical viewing angle is 114° , B typical viewing angle is 123° .
2. The viewing angle is defined as the off axis angle from the centerline where I_v is $\frac{1}{2}$ of the peak value.

Figure 8: Typical Polar Radiation Pattern at 120mA, $T_{sp}=25^{\circ}\text{C}$

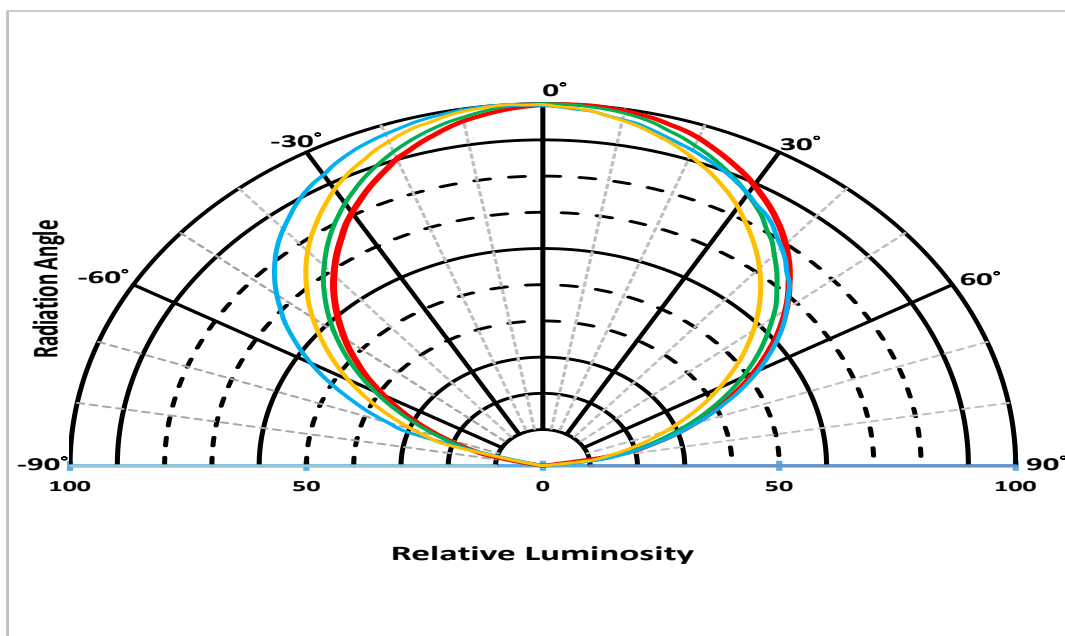

Typical Color Spectrum

Figure 9: Typical Color Spectrum at 120mA, Tsp=25°C

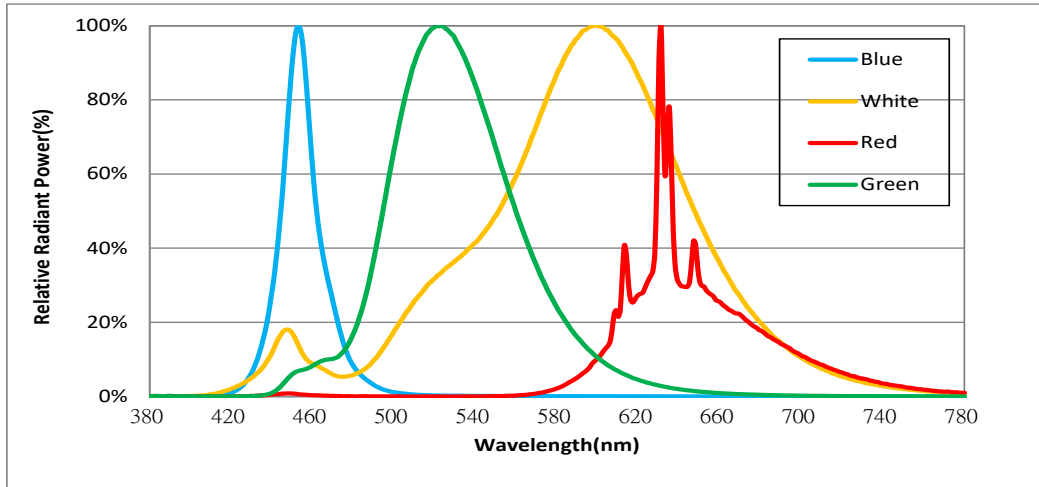
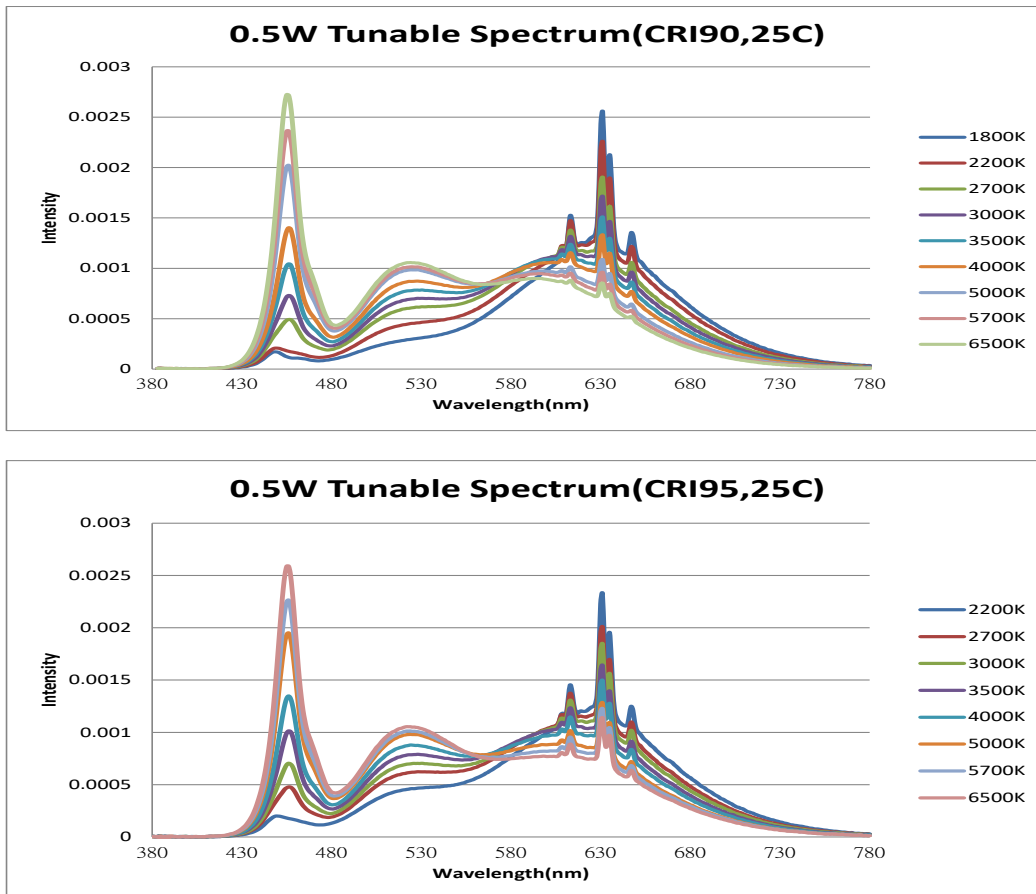
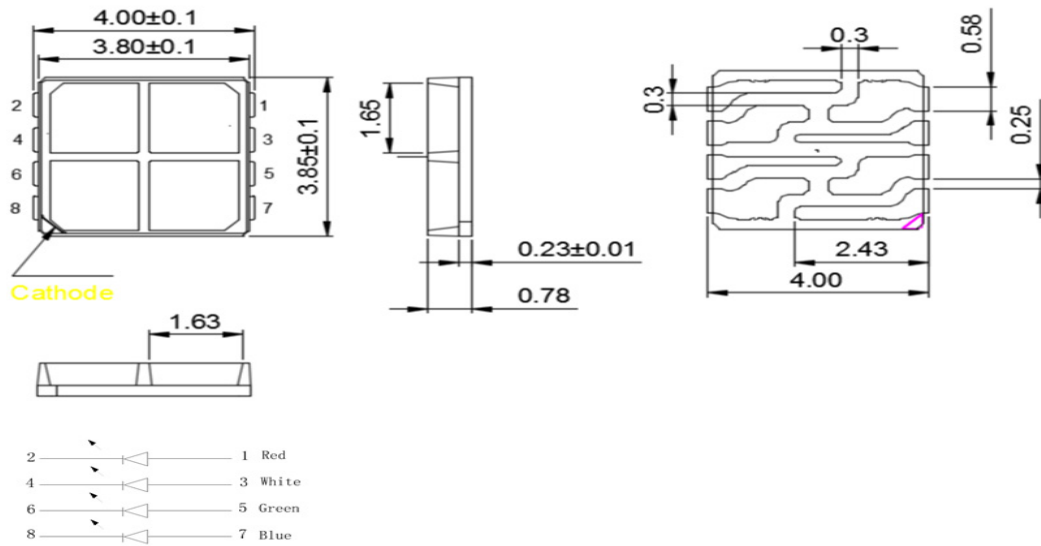

Figure 10: Tunable White Spectrum, Tsp=25°C



Mechanical Dimensions

Figure 11: Drawing for SMD 3838



Notes for Figure 11:

1. Drawings are not to scale.
2. Drawing dimensions are in millimeters.
3. Unless otherwise specified, tolerances are ± 0.10 mm.
4. The optical center of the LED emitter is nominally defined by the mechanical center of the emitter. The light emitting surface (LES) is centered on the mechanical center of the LED emitter to a tolerance of ± 0.2 mm

Recommended PCB Soldering Pad Pattern

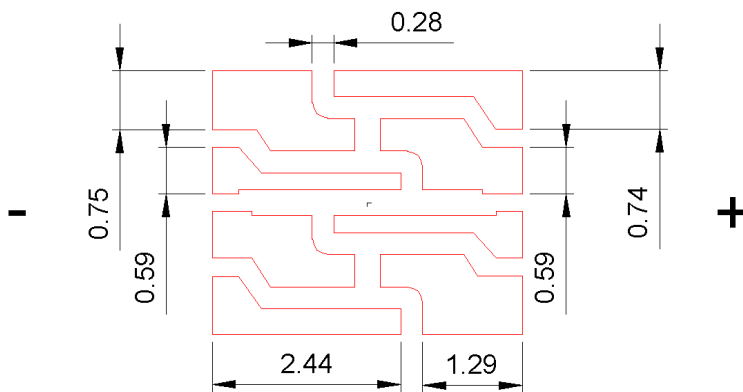

Reliability

Table 14: Reliability Test Items and Conditions

No.	Items	Reference Standard	Test Conditions	Drive Current	Test Duration	Units Failed/Tested
1	Moisture Sensitivity Level	J-STD-020D.1	$T_{\text{slid}} = 260^{\circ}\text{C}$, 10sec, Precondition: 85°C , 60%RH, 168hr		3 reflows	0/22
2	Low Temperature Storage	JESD22-A119	$T_{\text{a}} = -40^{\circ}\text{C}$		1000 hours	0/22
3	High Temperature Storage	JESD22-A103	$T_{\text{a}} = 105^{\circ}\text{C}$		1000 hours	0/22
4	Low Temperature Operating Life	JESD22-A108	$T_{\text{a}} = -40^{\circ}\text{C}$	120mA	1000 hours	0/22
5	Temperature Humidity Operating Life	JESD22-A101	$T_{\text{sp}} = 85^{\circ}\text{C}$, RH=85%	120mA	1000 hours	0/22
6	High Temperature Operating Life	JESD22-A108	$T_{\text{sp}} = 105^{\circ}\text{C}$, RGBW 4 channel all on	120mA(WRG) /80mA(B)	1000 hours	0/22
7	High Temperature Operating Life	JESD22-A108	$T_{\text{sp}} = 105^{\circ}\text{C}$, W & R 2 channel on	160mA	1000 hours	0/22
8	High Temperature Operating Life	JESD22-A108	$T_{\text{sp}} = 85^{\circ}\text{C}$, B channel on	160mA	1000 hours	0/22
9	Thermal Shock	JESD22-A104	$T_{\text{a}} = -40^{\circ}\text{C} \sim 100^{\circ}\text{C}$, Dwell : 15min; Transfer: 10sec		200 Cycles	0/22
10	Temperature Cycle	JESD22-A104	$T_{\text{a}} = -40^{\circ}\text{C} \sim 100^{\circ}\text{C}$, Dwell at extreme temperature: 15min; Ramp rate < $105^{\circ}\text{C}/\text{min}$		200 Cycles	0/22

Passing Criteria

Item	Symbol	Test Condition	Passing Criteria
Forward Voltage	Vf	120mA	$\Delta V_f < 10\%$
Luminous Flux	Iv	120mA	$\Delta I_v < 30\%$
Chromaticity Coordinates	(x, y)	120mA	$\Delta u'v' < 0.007$

Notes for Table 14:

1. Measurements are performed after allowing the LEDs to return to room temperature
2. T_{slid} : reflow soldering temperature; T_{a} : ambient temperature

Reflowing Characteristics

Figure 12 : Reflow Profile

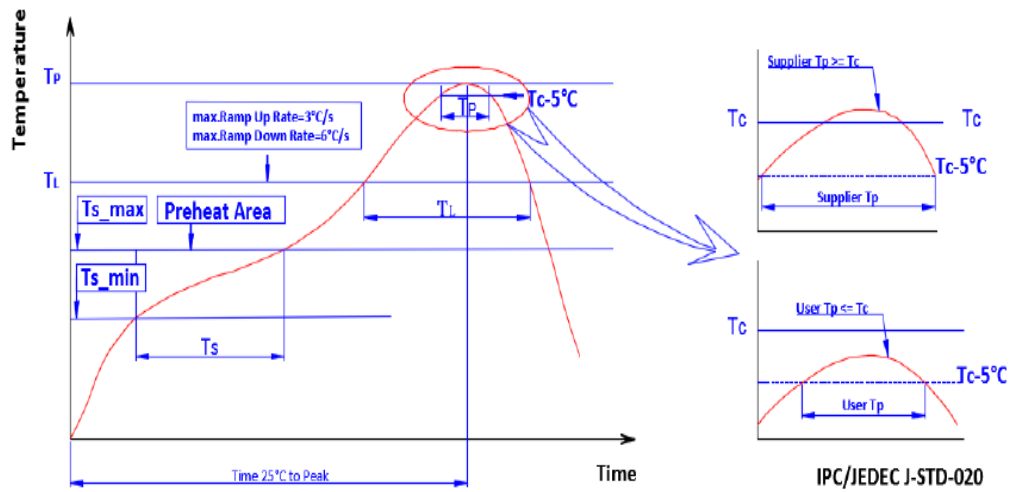

Profile Feature	Lead Free Assembly
Temperature Min. (T_{s_min})	160°C
Temperature Max. (T_{s_max})	205°C
Time (t_s) from T_{s_min} to T_{s_max}	60-150 seconds
Ramp-Up Rate (T_L to T_p)	3 °C/second
Liquidus Temperature (T_L)	220 °C
Time (T_L) Maintained Above T_L	60-150 seconds
Peak Temp (T_p)	260 °C max.
Time (T_p) Within 5 °C of the Specified Classification Temperature (T_c)	25 seconds max.
Ramp-Down Rate (T_p to T_L)	5 °C/second max.
Time 25 °C to Peak Temperature	10 minutes max.

Design Resources

Optical Source Models

Please contact your Bridgelux sales representative for assistance.

Precautions

CAUTION: CHEMICAL EXPOSURE HAZARD

Exposure to some chemicals commonly used in luminaire manufacturing and assembly can cause damage to the LED emitter. Please consult Bridgelux Application Note AN51 for additional information.

CAUTION: EYE SAFETY

Eye safety classification for the use of Bridgelux SMD LED emitter is in accordance with IEC specification EN62471: Photobiological Safety of Lamps and Lamp Systems. Please use appropriate precautions when the blue light is on since blue light poses eye safety risk. The Blue is classified as Risk Group 2 when operated at or below the maximum drive current. It is important that employees working with LEDs are trained to use them safely.

CAUTION: RISK OF BURN

Do not touch the SMD LED emitter during operation. Allow the emitter to cool for a sufficient period of time before handling. The SMD LED emitter may reach elevated temperatures such that could burn skin when touched.

Disclaimers

MINOR PRODUCT CHANGE POLICY

The rigorous qualification testing on products offered by Bridgelux provides performance assurance. Slight cosmetic changes that do not affect form, fit, or function may occur as Bridgelux continues product optimization.

CAUTION

CONTACT WITH LIGHT EMITTING SURFACE (LES)

Avoid any contact with the LES. Do not touch the LES of the emitter or apply stress to the LES. Contact may cause damage to the emitter

Optics and reflectors must not be mounted in contact with the LES.

STANDARD TEST CONDITIONS

Unless otherwise stated, LED emitter testing is performed at the nominal drive current.

About Bridgelux: Bridging Light and Life™

At Bridgelux, we help companies, industries and people experience the power and possibility of light. Since 2002, we've designed LED solutions that are high performing, energy efficient, cost effective and easy to integrate. Our focus is on light's impact on human behavior, delivering products that create better environments, experiences and returns—both experiential and financial. And our patented technology drives new platforms for commercial and industrial luminaires.

For more information about the company, please visit
bridgelux.com
twitter.com/Bridgelux
facebook.com/Bridgelux
WeChat ID: BridgeluxInChina



46410 Fremont Boulevard
Fremont, CA 94538 U.S.A.
Tel (925) 583-8400
www.bridgelux.com

© 2024 Bridgelux, Inc. All rights reserved. Product specifications are subject to change without notice. Bridgelux and the Bridgelux stylized logo design are registered trademarks of Bridgelux, Inc. All other trademarks are the property of their respective owners.