

Bridgelux® Vesta® Series RGBW Strip

Product Data Sheet DS585



Product Feature Map

Bridgelux Vesta Series RGBW Strip are fully engineered devices that provide consistent thermal and optical performance on an engineered mechanical platform. The Strip products incorporate several features to simplify design integration and assembly. Please visit www.bridgelux.com for more information on the Vesta Series family of products.

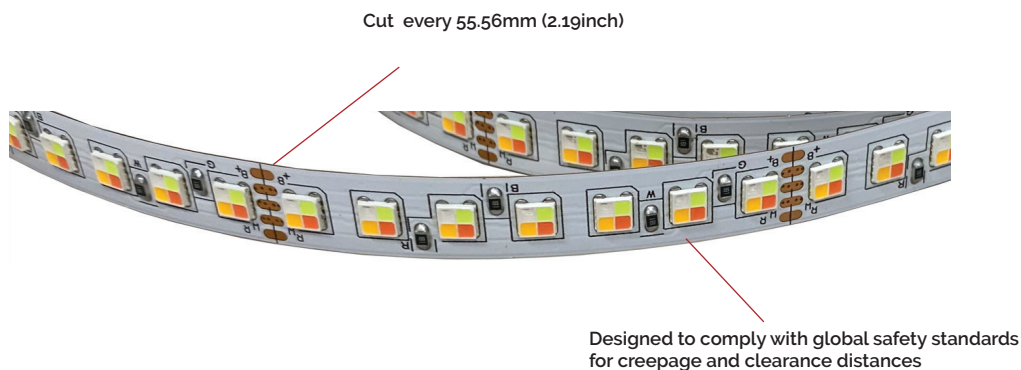

Product Nomenclature

The part number designation for Bridgelux Vesta Series RGBW Strip is explained as follows:

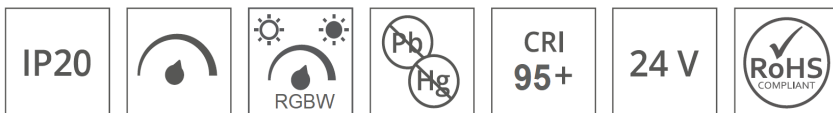
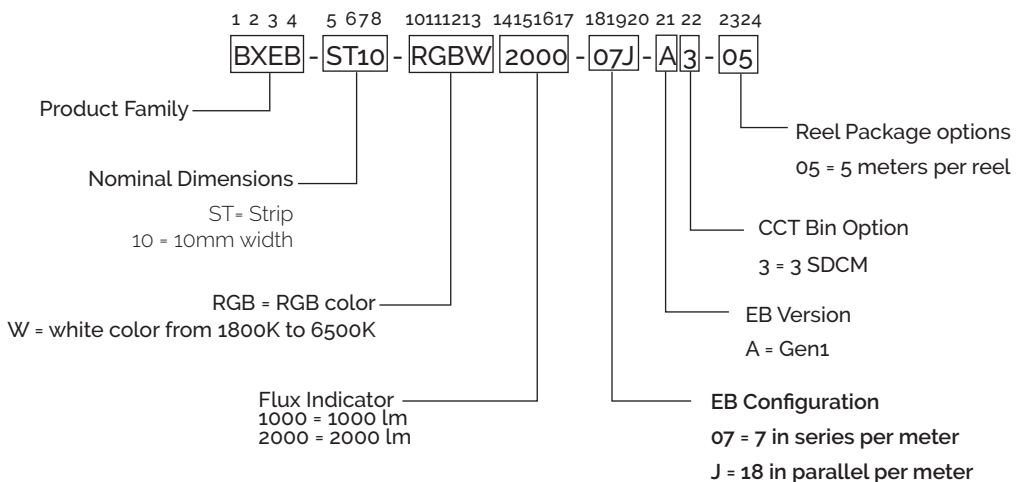

Product Selection Guide

The following product configurations are available:

Table 1: Selection Guide, White Pulsed Measurement Data at 1 meter (3.28ft) length ($T_j=T_c=25^\circ\text{C}$)

Part Number	Nominal CCT ¹ (K)	CRI ²	Nominal If Total (mA)	Drive Current Ratio Per Channel				Forward Voltage ³ (V)	Typical Power (W)	Typical Pulsed Flux ^{3, 4, 5} (lm)	Typical Efficacy (lm/W)
				White	Red	Green	Blue				
BXEB-ST10-RGBW 1000-07J-A3-05	1800	95	400	40.78%	53.33%	5.88%	0.00%	24	9.6	803	84
	2200		400	44.71%	42.98%	11.53%	0.78%	24	9.6	889	93
	2700		400	44.71%	35.10%	17.18%	3.02%	24	9.6	949	99
	3000		400	44.71%	30.39%	20.27%	4.63%	24	9.6	979	102
	3500		400	43.14%	26.47%	23.53%	6.86%	24	9.6	990	104
	4000		400	40.00%	23.53%	27.29%	9.18%	24	9.6	999	105
	5000		400	34.90%	20.00%	31.49%	13.61%	24	9.5	988	105
	5700		400	32.94%	18.00%	33.06%	16.00%	24	9.5	983	104
	6500		400	30.20%	16.47%	34.71%	18.63%	24	9.5	978	103
BXEB-ST10-RGBW 2000-07J-A3-05	1800	95	700	40.78%	53.33%	5.88%	0.00%	24	16.9	1289	76
	2200		700	44.71%	42.98%	11.53%	0.78%	24	16.7	1425	85
	2700		700	44.71%	35.10%	17.18%	3.02%	24	16.8	1518	91
	3000		700	44.71%	30.39%	20.27%	4.63%	24	16.7	1561	94
	3500		700	43.14%	26.47%	23.53%	6.86%	24	16.6	1581	95
	4000		700	40.00%	23.53%	27.29%	9.18%	24	16.4	1593	97
	5000		700	34.90%	20.00%	31.49%	13.61%	24	16.4	1566	96
	5700		700	32.94%	18.00%	33.06%	16.00%	24	16.3	1555	96
	6500		700	30.20%	16.47%	34.71%	18.63%	24	16.4	1548	94

Notes for Table 1:

1. Nominal CCT as defined by ANSI C78.377-2011.
2. Listed CRIs are minimum values and include test tolerance.
3. Products tested under pulsed condition (10ms pulse width) at nominal drive current where T_j (junction temperature) = T_c (case temperature) = 25°C .
4. Typical performance values are provided as a reference only and are not a guarantee of performance.
5. Bridgelux maintains a $\pm 7.5\%$ tolerance on flux measurements

Product Selection Guide

The following product configurations are available:

Table 2: Selection Guide, RGBW Pulsed Measurement Data at 1 meter (3.28ft) length ($T_j=T_c=25^\circ\text{C}$)

Part Number	Color	Nominal Drive Current (mA)	Forward Voltage ³ (V)	Typical Power (W)	Typical Pulsed Flux ^{3,4,5} (lm)	Dominant Wavelength (nm)
BXEB-ST10-RGBW1000-07J-A3-05	Red	400	24	9.6	411	617
	Green	400	24	9.8	1501	536
	Blue	400	24	10.0	180	463
	White	400	24	9.8	1229	2500K 70CRI
BXEB-ST10-RGBW2000-07J-A3-05	Red	700	24	17.5	664	617
	Green	700	24	18.0	2440	536
	Blue	700	24	18.1	278	463
	White	700	24	18.0	2018	2500K 70CRI

Notes for Table 2:

1. Nominal CCT as defined by ANSI C78.377-2011.
2. Listed CRIs are minimum values and include test tolerance.
3. Products tested under pulsed condition (10ms pulse width) at nominal drive current where T_j (junction temperature) = T_c (case temperature) = 25°C .
4. Typical performance values are provided as a reference only and are not a guarantee of performance.
5. Bridgelux maintains a $\pm 7.5\%$ tolerance on flux measurements
6. White color is targeted at CCT of 2500K, 70CRI.

Absolute Maximum Ratings

Table 3: Maximum Ratings at 1 meter (3.28ft) length

Parameter	Maximum Rating							
Storage Temperature	-40°C to +85°C							
Operating Case Temperature (T _c)	85°C							
Soldering Temperature	350°C or lower for a maximum of 5 seconds							
	BXEB-ST10-RGBW1000-07J-A3-05				BXEB-ST10-RGBW2000-07J-A3-05			
	White	Red	Green	Blue	White	Red	Green	Blue
Maximum Drive Current Per Color (mA)	450	450	450	450	900	900	900	900

Table 4: Dimming White with CRI95 Ratio

CCT	1800K	2200K	2700K	3000K	3500K	4000K	5000K	5700K	6500K
Color									
W	40.78%	44.71%	44.71%	44.71%	43.14%	40.00%	34.90%	32.94%	30.20%
R	53.33%	42.98%	35.10%	30.39%	26.47%	23.53%	20.00%	18.00%	16.47%
G	5.88%	11.53%	17.18%	20.27%	23.53%	27.29%	31.49%	33.06%	34.71%
B	0.00%	0.78%	3.02%	4.63%	6.86%	9.18%	13.61%	16.00%	18.63%

Performance Curves

Figure 1: Relative Current Ratio vs. CCT at CRI 95 ($T_c = 25^\circ\text{C}$)

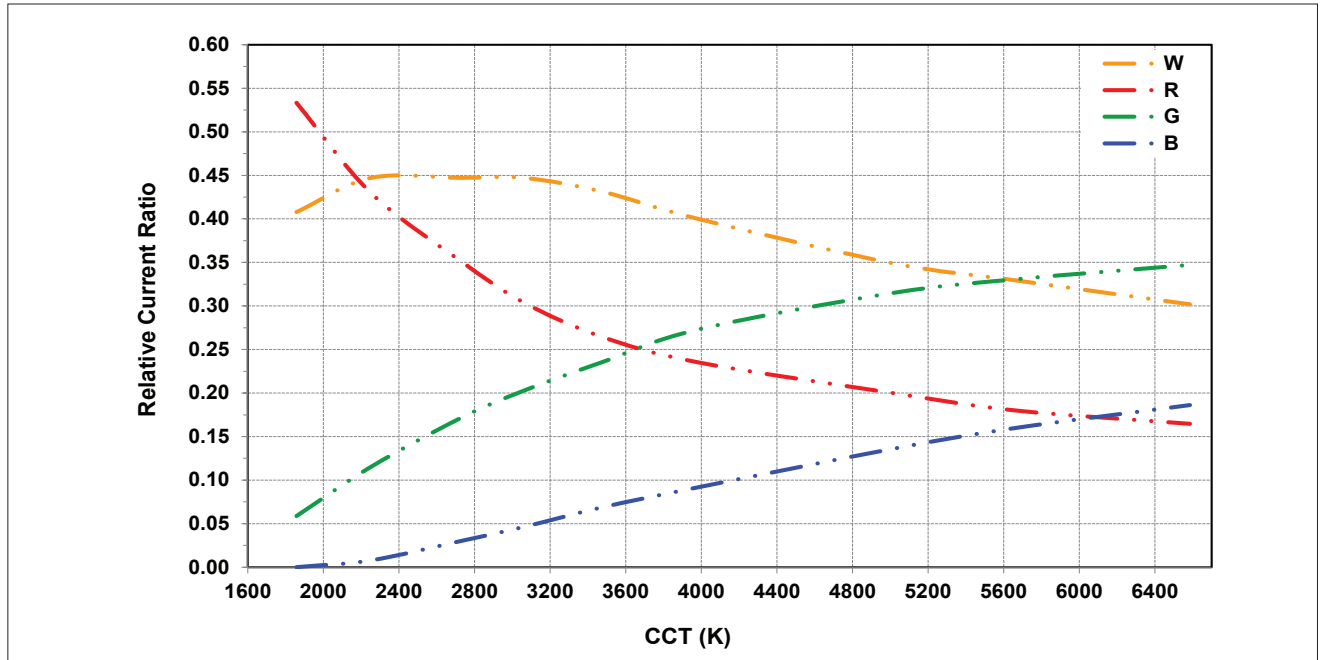
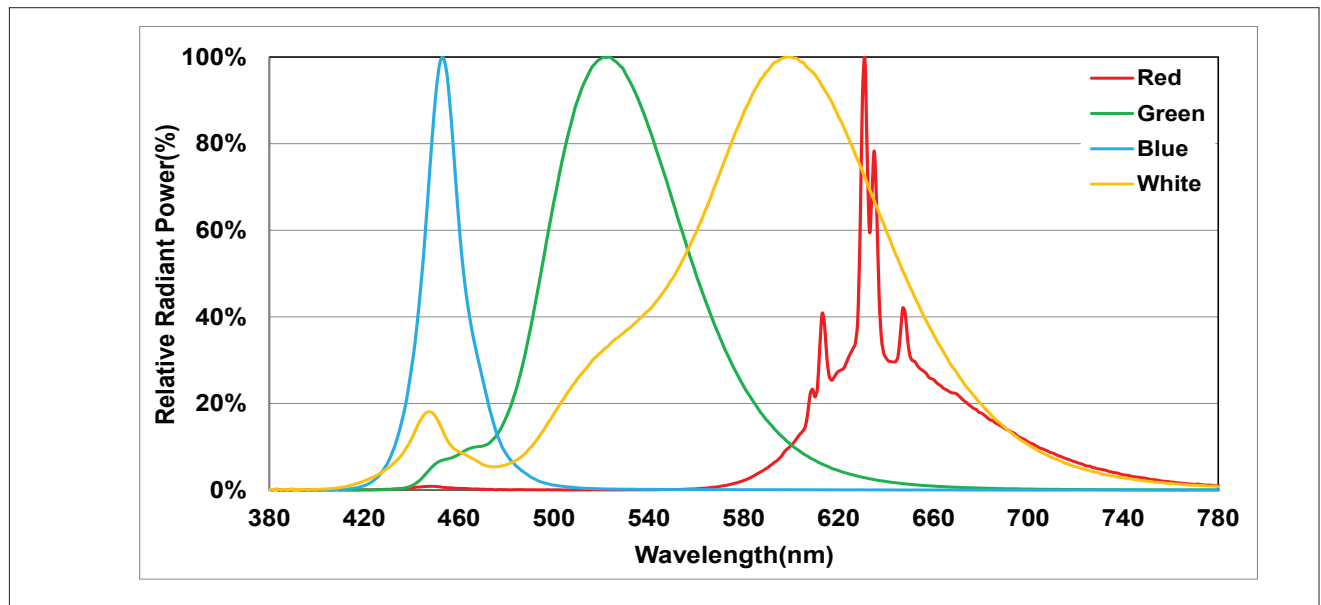

Figure 2: Typical Color Spectrum (RGBW)



Note for Figure 2:

1. Color spectra measured at nominal current for $T_c = 25^\circ\text{C}$.

Performance Curves

Figure 3: Typical Color Spectrum (White CCT, at $T_c = 25^\circ\text{C}$)

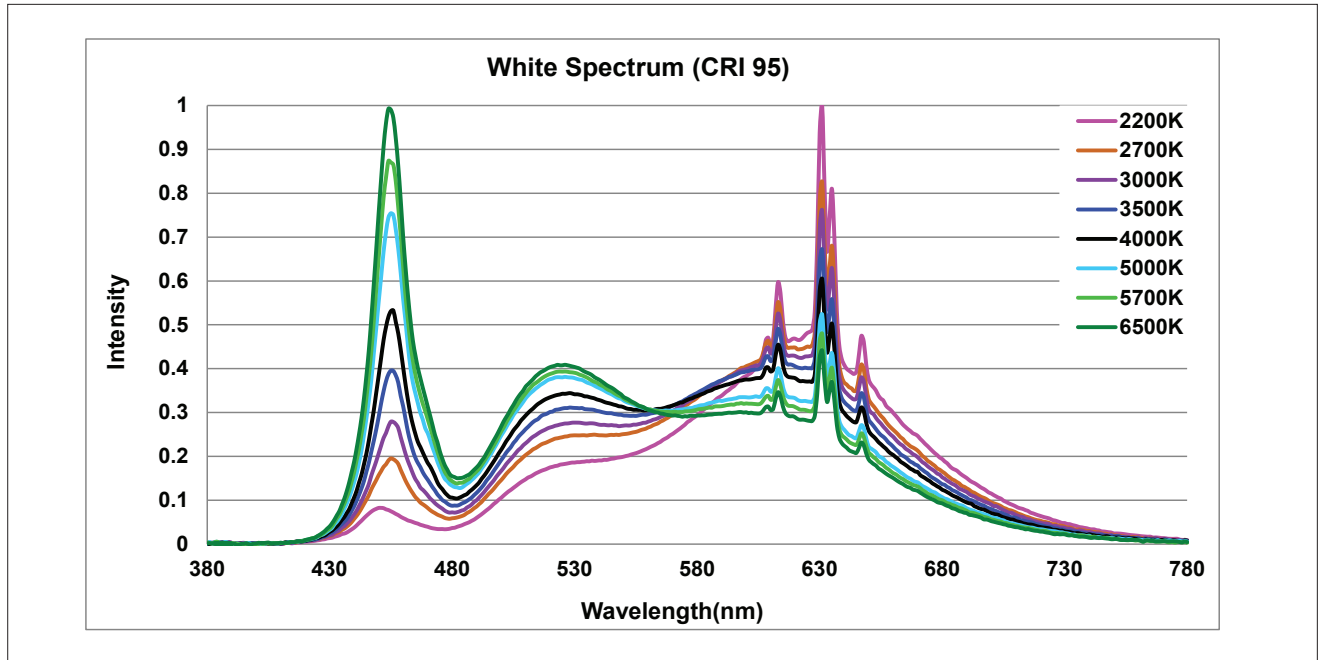

Note for Figure 3:

1. Color spectra measured at nominal current for $T_c = 25^\circ\text{C}$.

Figure 4: Chromaticity Coordinate Group (Color Targeted at $T_c = 25^\circ\text{C}$)

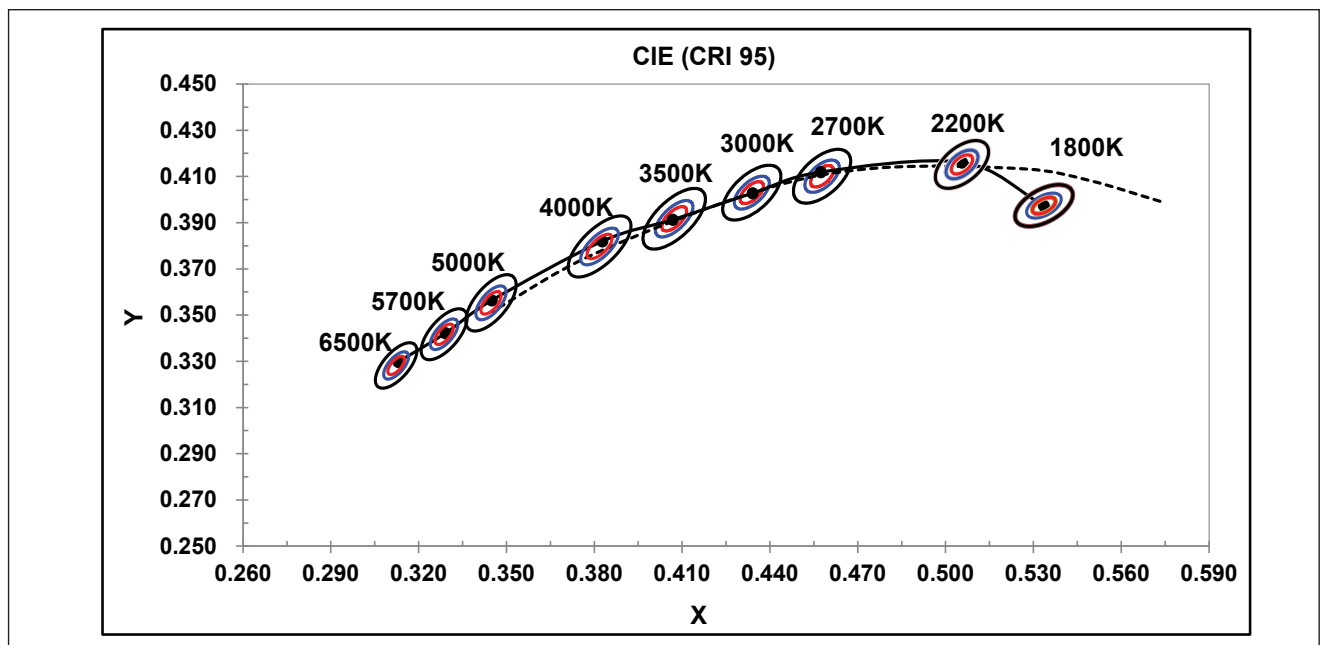

Product Bin Definitions

Table 5: RGW MacAdam Ellipse Color Bin Definitions

Color	Center Point		Major Axis	Minor Axis	Ellipse Rotation Angle	Color Bin
	X	Y				
R	0.6769	0.3139	0.01854	0.00828	5.0	6
G	0.2488	0.6094	0.03084	0.00960	73.0	6
W	0.4870	0.4320	0.00810	0.00420	53.7	3
			0.01620	0.00840	53.7	3/A/B/C/D

Notes for Table 5

1. Color binning at $T_c = 25^\circ\text{C}$ unless otherwise specified
2. Bridgelux maintains a tolerance of ± 0.007 on x and y color coordinates.

Figure 5: Chromaticity Coordinate Group (Color Targeted at $T_c=25^\circ\text{C}$)

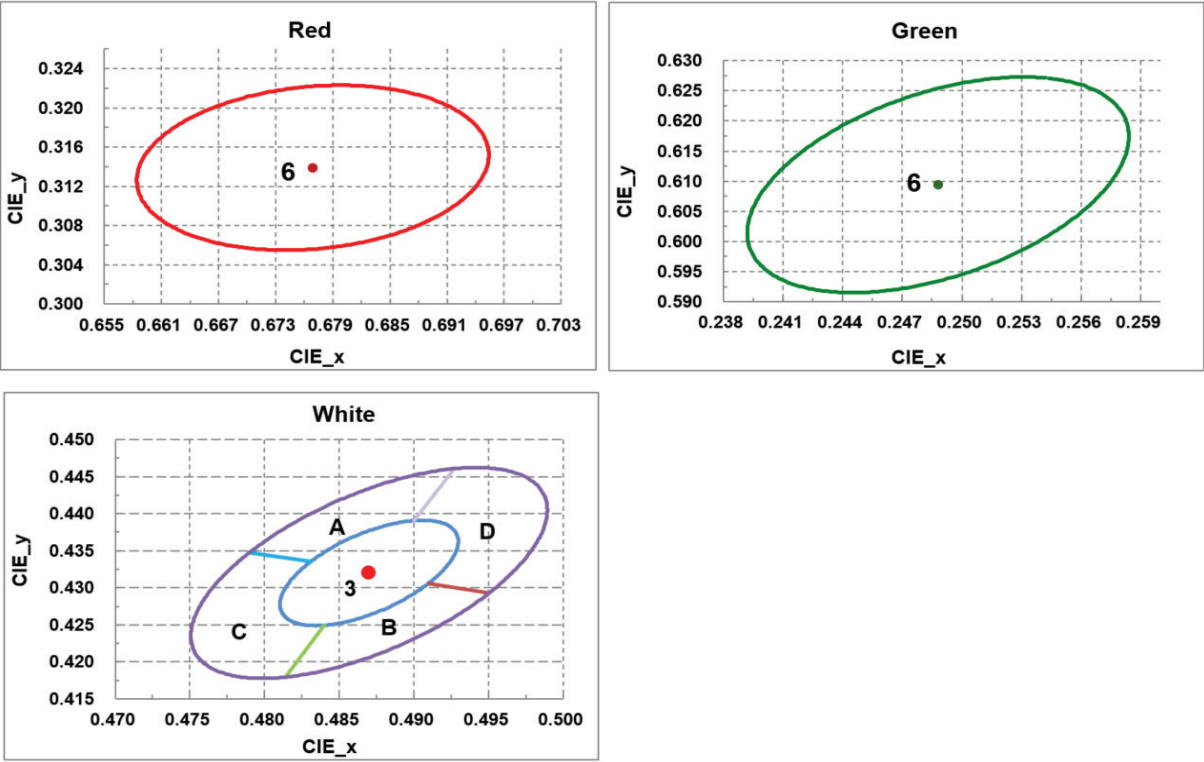

Mechanical Dimensions

Figure 6: Drawing Overview for RGBW Tape

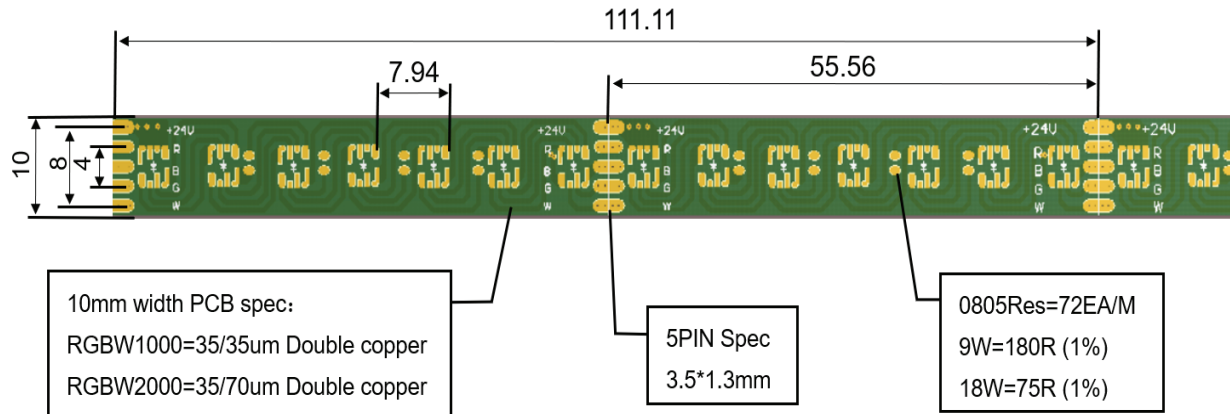

Note for Figure 6:

1. Solder pads are labeled "+" to denote positive polarity, and "-" to denote negative polarity.
2. Drawing dimensions are in millimeters.

Table 6: Strip Module Dimensions

Parameter	BXEB-ST10-RGBW1000-07J-A3-05	BXEB-ST10-RGBW2000-07J-A3-05
Linear length per reel	5,000 mm	
Linear width	10 mm	
Overall thickness	1.35 mm	
PCB thickness	0.55 mm	

Note for Table 6:

1. Standard length is 5 meters per reel. Additional lengths may be available upon request, please consult your Bridgelux sales representative.

Packaging and Labeling

Figure 7: EB Series Packaging and Labeling

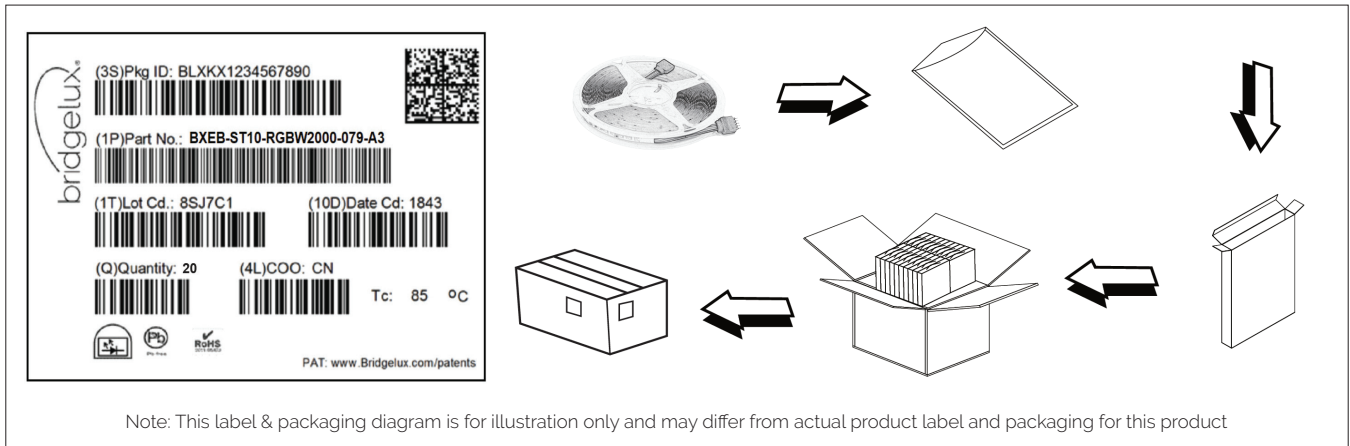

Table 7: Packaging Structure

Box Parameter	BXEB-ST10-RGBW1000-07J-A3-05	BXEB-ST10-RGBW2000-07J-A3-05
Quantity	20	
Dimension	33cm x 25cm x 18.5cm	

Figure 8: Product Labeling

Bridgelux Vesta Series RGBW Strip modules contain a label on the front to help with product identification. In addition to the product identification markings, Bridgelux Vesta Series RGBW EB modules also contain markings for internal Bridgelux manufacturing use only. The image below shows which markings are for customer use and which ones are for Bridgelux internal use only. The Bridgelux internal manufacturing markings are subject to change without notice, however these will not impact the form, function or performance of the module.



Vesta Series RGBW Strip
1 meter 2000lm 24V

Customer Use- 2D Barcode
Scannable barcode provides
product part number and other
Bridgelux internal production
information.

Connector Feature Map

Figure 9: Connector Product Nomenclature and Photo

The part number designation for Bridgelux Solderless Connector Assemblies is explained as follows.

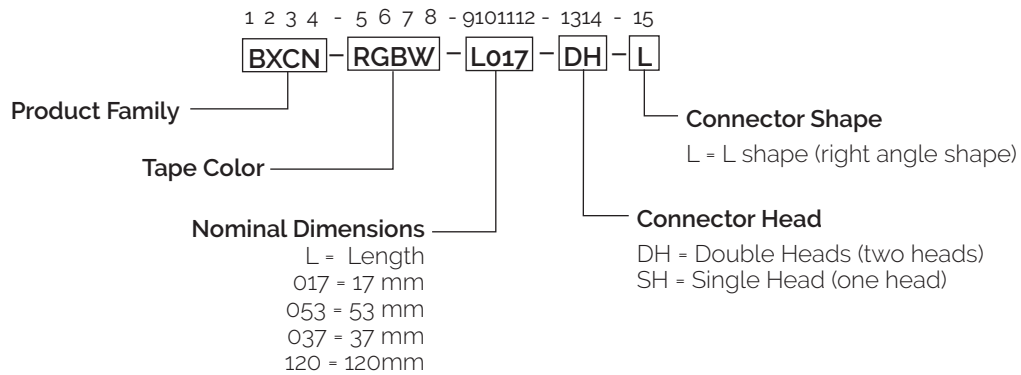

Four Connector Types

Connector Part Numbers



Table 8: Connector Selection Guide

Bridgelux Connector Part Number	Connector Description	Connector Size (L x W x T) (mm x mm x mm)
BXCN-RGBW-L017-DH	Double Heads 17mm Length without wires	17x12x5
BXCN-RGBW-L053-DH	Double Heads 53mm length with wires	52.6x14x7
BXCN-RGBW-L037-DH-L	Double Head L shape 37mm length with wires	37x37x7
BXCN-RGBW-L120-SH	Single Head 120mm Length with wires	120x12x5

Note for Table 8:

1. Additional connector designs can be requested. Please consult your Bridgelux sales representative.

Connector Installation

Figure 10: Connector Installation Guide

Bridgelux 5-pin led light connectors are suitable for 10mm RGBW LED strip lights. The unique design is convenient for inspection or reinstallation, just use a suitable screwdriver to pry it open, and can be reused and expanded.

1. Insert wires into the guide slot and then press cap down
2. To cut Flex Tape, leave the 3M backing in place and use a sharp utility knife or razor blade. Cut along a straight line on a stable surface to achieve the desired size.
3. Must Completely cut off the copper foil from one section of the tape to ensure full contact with the connector's pin needles. This will result in the loss of one cuttable tape segment.
4. Align the Soldering Pads of the light strip surface with the pins on the connector. Align the positive and negative poles of the light strip (see photo on the right)
5. Close the cap. Wire to led strip connection complete. Due to the limited LED spacing, one LED near the connector head will be partially covered by the transparent connector after installation. However, this has minimal impact on the overall LED tape flux.

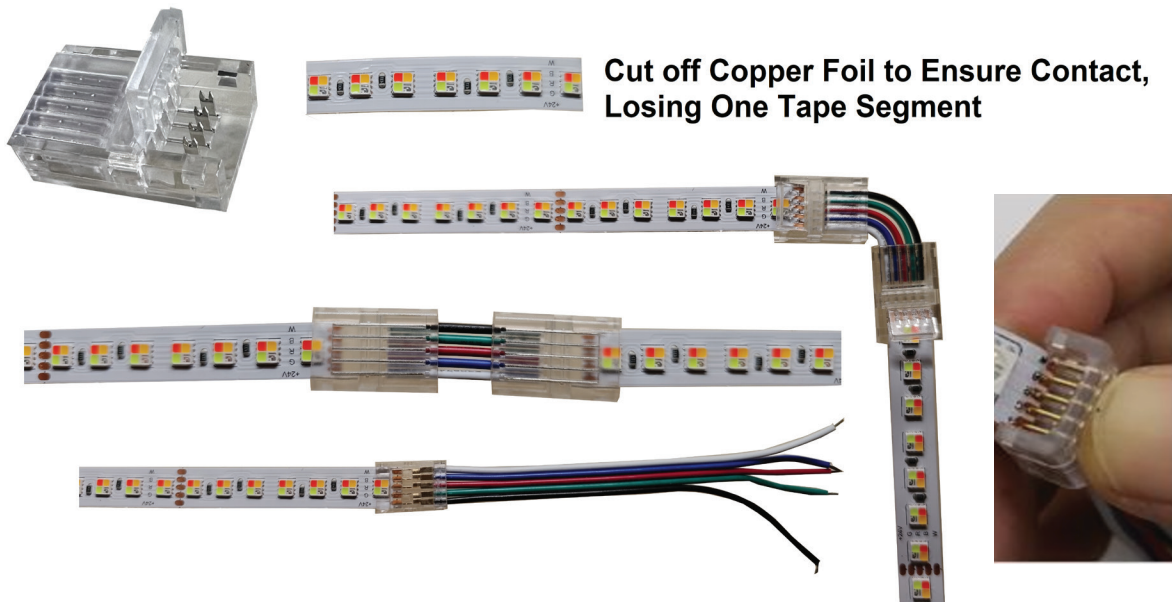

Connector Mechanical Dimensions

Figure 11: Mechanical Drawing for BXCN-RGBW-L017-DH

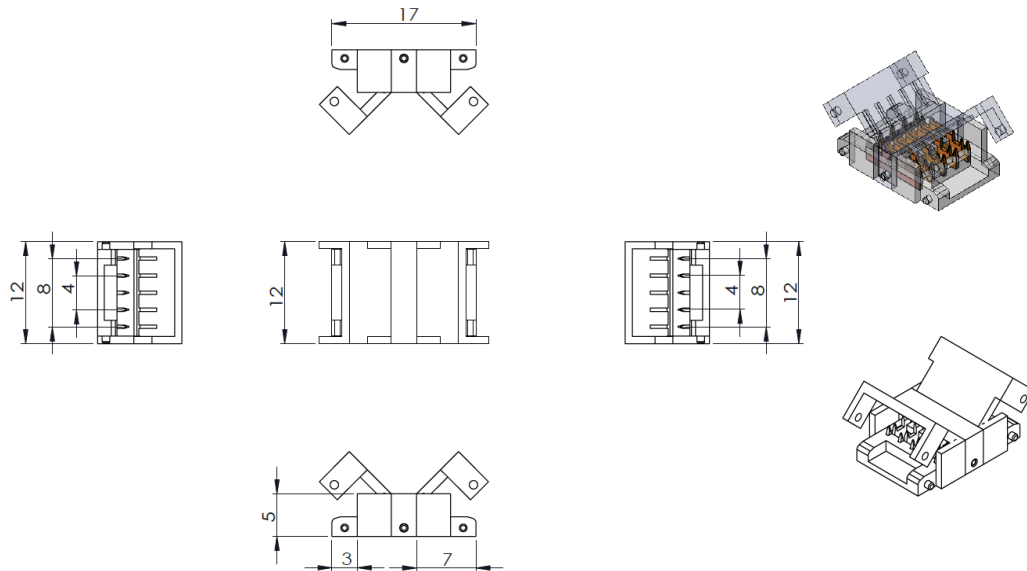
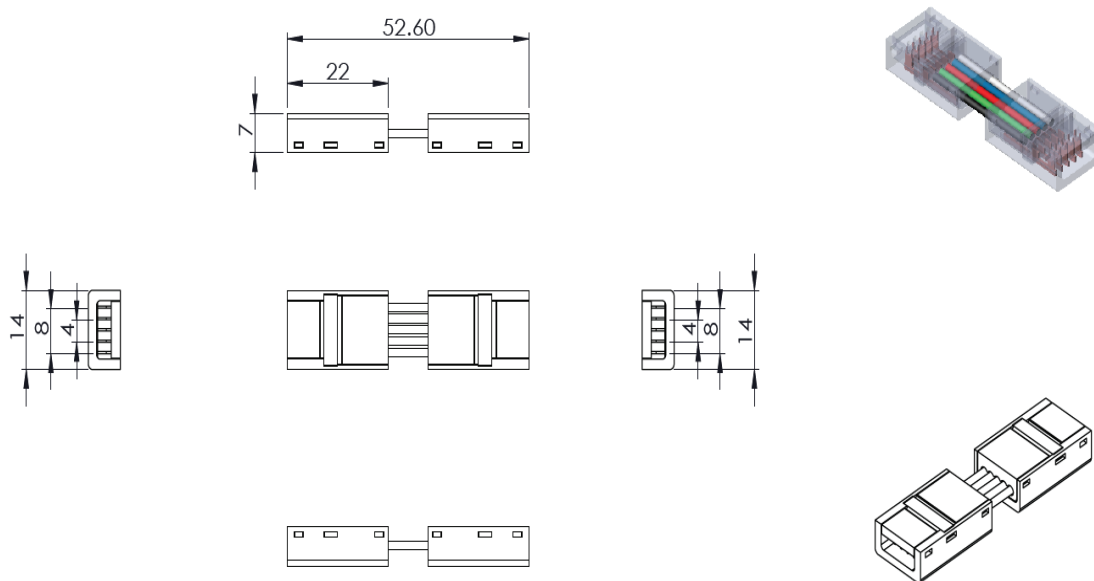

Figure 12: Mechanical Drawing for BXCN-RGBW-L053-DH



Notes for Figures 11 & 12:

1. 5 Pins; PC housing material; 12mm width workable strip; RGBW strip color; 22AWG wire gauge.
2. Drawings are not to scale, and drawing dimensions are in millimeters.
3. Unless otherwise specified, tolerances are ± 0.15 mm.

Connector Mechanical Dimensions

Figure 13: Mechanical Drawing for BXCN-RGBW-L037-DH-L

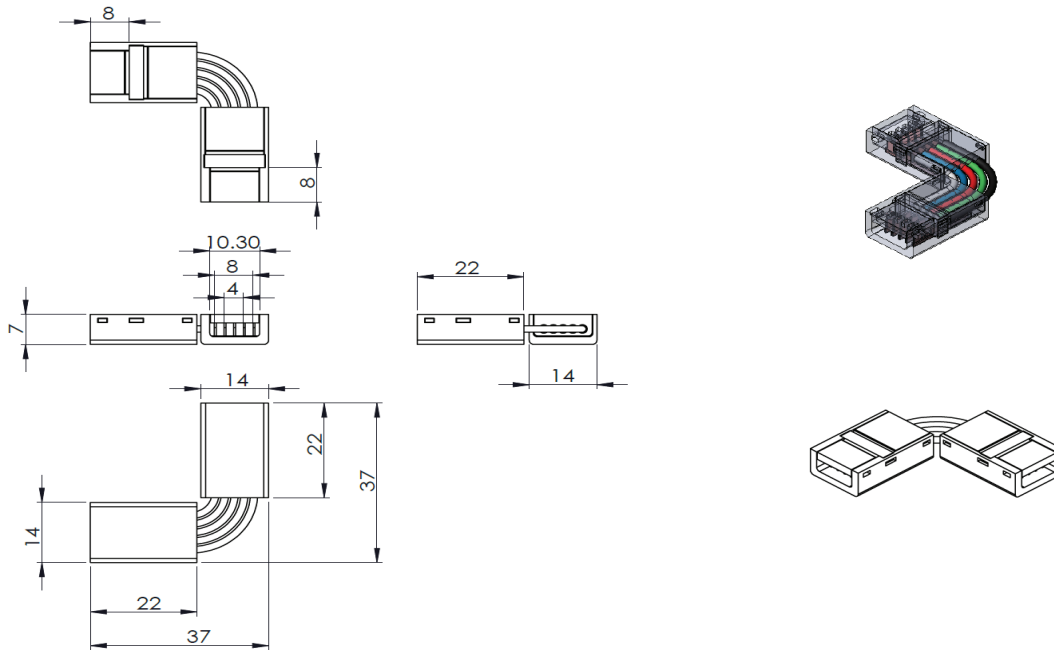
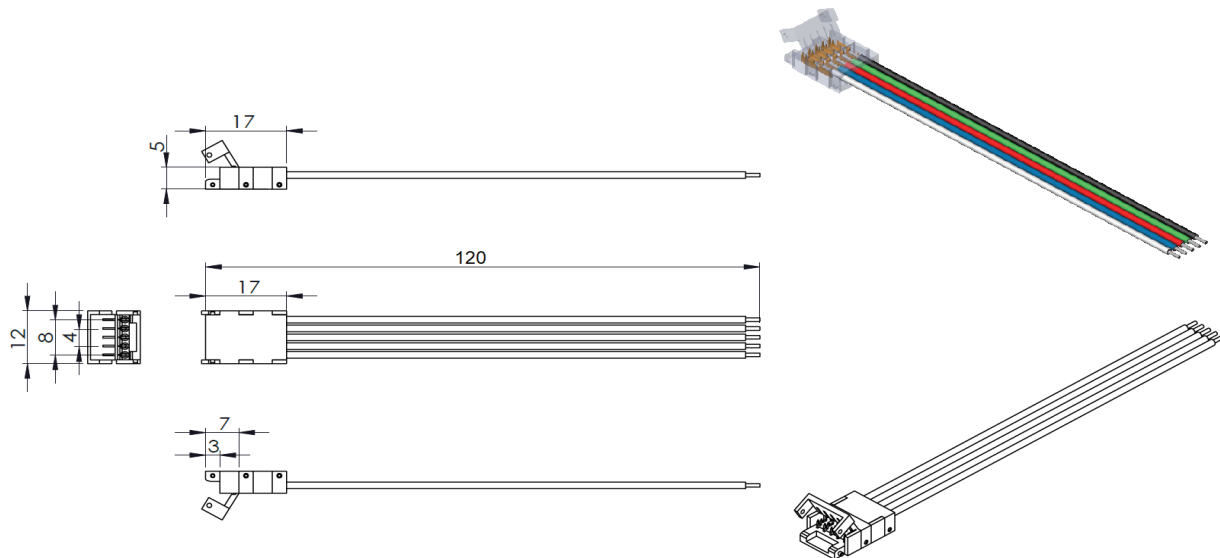

Figure 14: Mechanical Drawing for BXCN-RGBW-L120-SH



Notes for Figures 13 & 14:

1. 5 Pins; PC housing material; 12mm width workable strip; RGBW strip color; 22AWG wire gauge.
2. Drawings are not to scale, and drawing dimensions are in millimeters.
3. Unless otherwise specified, tolerances are ± 0.15 mm.

Design Resources

Application Notes

Vesta Series RGBW Strip are intended for use in dry, indoor applications. Bridgelux has developed a comprehensive set of application notes and design resources to assist customers in successfully designing with the Vesta Series product family of RGBW Strip products. For a list of resources under development, visit www.bridgelux.com.

Optical Source Models

Optical source models and ray set files are available for all Bridgelux products. For a list of available formats, visit www.bridgelux.com.

3D CAD Models

Three dimensional CAD models depicting the product outline of all Bridgelux Vesta Series RGBW Strip are available in both IGS and STEP formats. Please contact your Bridgelux sales representative for assistance.

LM80

Please contact your Bridgelux sales representative for more information.

Precautions

CAUTION: CHEMICAL EXPOSURE HAZARD

Exposure to some chemicals commonly used in luminaire manufacturing and assembly can cause damage to the RGBW EB. Please consult Bridgelux Application Note for additional information.

CAUTION: EYE SAFETY

The Bridgelux Vesta series RGBW EB emits visible light, that, under certain circumstances, could be harmful to the eye. Proper safeguards must be used.

CAUTION: RISK OF BURN

Do not touch the Vesta Series RGBW EB during operation. Allow the RGBW EB to cool for a sufficient period of time before handling. The Vesta Series RGBW EB may reach elevated temperatures such that could burn skin when touched.

CAUTION

CONTACT WITH LIGHT EMITTING SURFACE (LES)

Avoid any contact with the LES. Do not touch the LES of the RGBW EB or apply stress to the LES (yellow phosphor resin area). Contact may cause damage to the RGBW EB.

Optics and reflectors must not be mounted in contact with the LES (yellow phosphor resin area). Optical devices may be mounted on the top surface of the Vesta Series RGBW EB. Use the mechanical features of the RGBW EB housing, edges and/or mounting holes to locate and secure optical devices as needed.

Disclaimers

STANDARD TEST CONDITIONS

Unless otherwise stated, RGBW EB testing is performed at the nominal drive current.

MINOR PRODUCT CHANGE POLICY

The rigorous qualification testing on products offered by Bridgelux provides performance assurance. Slight cosmetic changes that do not affect form, fit, or function may occur as Bridgelux continues product optimization.

About Bridgelux: Bridging Light and Life™

At Bridgelux, we help companies, industries and people experience the power and possibility of light. Since 2002, we've designed LED solutions that are high performing, energy efficient, cost effective and easy to integrate. Our focus is on light's impact on human behavior, delivering products that create better environments, experiences and returns—both experiential and financial. And our patented technology drives new platforms for commercial and industrial luminaires.

For more information about the company, please visit

bridgelux.com

twitter.com/Bridgelux

facebook.com/Bridgelux

youtube.com/user/Bridgelux

linkedin.com/company/bridgelux

WeChat ID: BridgeluxInChina



46410 Fremont Blvd
Fremont, CA 94538 USA
Tel (925) 583-8400
www.bridgelux.com

© 2024 Bridgelux, Inc. All rights reserved 2024. Product specifications are subject to change without notice. Bridgelux, the Bridgelux stylized logo design and Vesta are registered trademarks of Bridgelux, Inc. All other trademarks are the property of their respective owners.

Bridgelux Vesta Series RGBW Strip Product Data Sheet DS585 Rev. A (12/2024)