

Bridgelux® SMD 3838 Thrive97 3V

Product Data Sheet DS1414

Introduction

SMD 3838 Thrive97

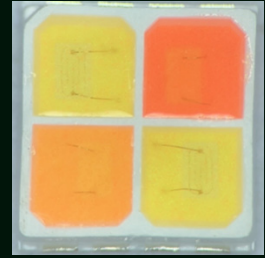

The Bridgelux SMD 3838 low power LED is cold-color targeted, which ensures that the LEDs fall within their specified color bin at the typical application conditions of 25°C. The SMD 3838 is ideal as a drop-in replacement for emitters with an industry standard 3.8mm x 3.8mm footprint.

Features

- Industry-standard 3838 footprint
- RoHS compliant and lead free
- Triple CCT 4 in 1
- Triple CCT color tunable along BBC to mix 2700K-6500K
- Engineered spectra to closely match natural light
- R1-R15 > 90, high CRI, Rf and Rg values

Benefits

- Natural and vivid color rendering
- Lower operating and manufacturing cost
- Ease of design and rapid go-to-market
- Compliant with environmental standards
- Design flexibility

Contents

Product Feature Map	2
Product Selection Guide	3
Performance at Used Drive Currents	4
Spectrum Characteristics	5
Absolute Maximum Ratings	11
Product Bin Definitions	13
Performance Curves	14
Typical Radiation Pattern	16
Mechanical Dimensions	17
Reliability	18
Reflowing Characteristics	19
Packaging	20
Design Resources	22
Precautions	22
Disclaimers	22
About Bridgelux	23

Product Feature Map

Bridgelux SMD LED products come in industry standard package sizes . These LEDs are optimized for cost and performance, helping to ensure highly competitive system lumen per dollar performance while addressing the stringent efficacy and reliability standards required for modern lighting applications.

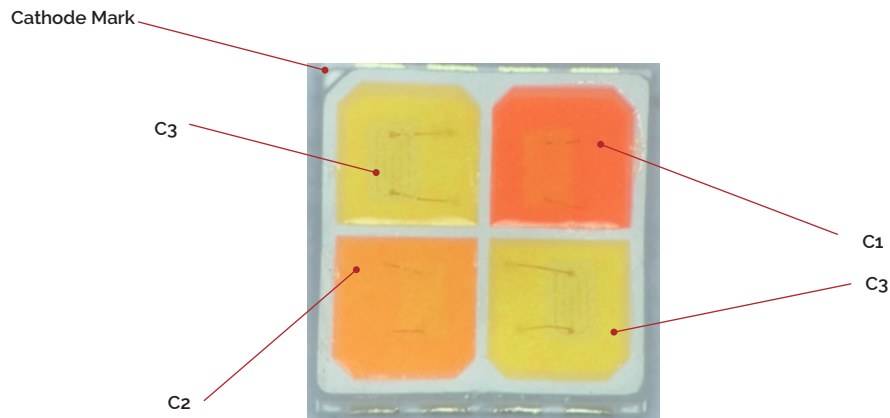

Product Nomenclature

The part number designation for Bridgelux SMD 3838 is explained as follows:

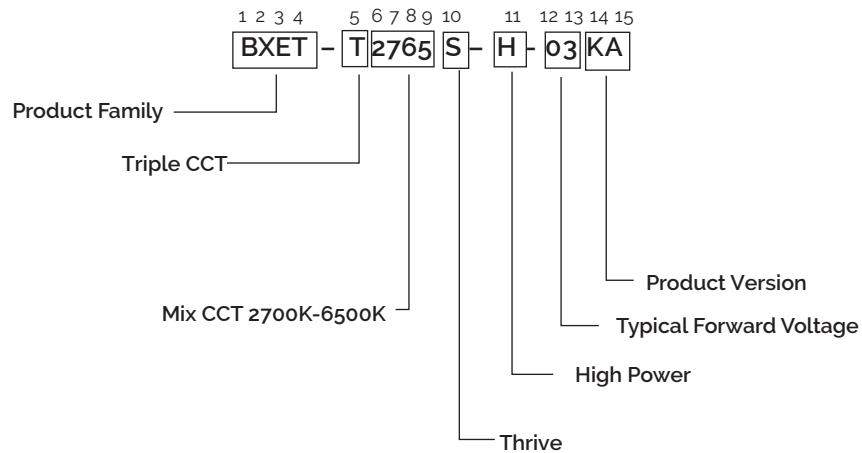

Product Selection Guide

The following product configurations are available:

Table 1: Selection Guide, 3838 pulsed Measurement Data at 60mA ($T_j = T_{sp} = 25^\circ\text{C}$)

Color ¹	Nominal Drive Current (mA)	Forward Voltage ^{2,3} (V)			Typical Pulsed Flux (lm) ^{2,3}
		Min	Typical	Max	
C1	60	2.8	2.89	3.2	18.2
C2	60	2.8	2.89	3.2	23.3
C3 ⁴	60	2.8	2.91	3.2	24.5

Table 2: Selection Guide, 3838 pulsed Measurement Data at 60mA ($T_j = T_{sp} = 55^\circ\text{C}$)

Color ¹	Nominal Drive Current (mA)	Forward Voltage ^{2,3} (V)			Typical Pulsed Flux (lm) ^{2,3}
		Min	Typical	Max	
C1	60	2.76	2.86	3.16	17.5
C2	60	2.76	2.86	3.16	22.5
C3 ⁴	60	2.76	2.87	3.16	23.5

Notes for Tables 1 & 2:

1. Products tested under pulsed condition (10ms pulse width) at nominal drive current where $T_j = T_{sp} = 25^\circ\text{C}$.
2. Bridgelux maintains a $\pm 7.5\%$ tolerance on luminous flux measurements, $\pm 0.1\text{V}$ tolerance on forward voltage measurements for the SMD 3838.
3. Typical pulsed test performance values are provided as reference only and are not a guarantee of performance.
4. The luminous flux (lm) is based on both C3 lighting up simultaneously in parallel.

Performance at Each CCT

Table 3: Tunable White

Power	CCT	C1 ratio	C2 ratio	C3 ratio	C3 ratio	C1 Drive Current (mA)	C2 Drive Current (mA)	C3 Drive Current (mA)	C3 Drive Current (mA)	CIE-X ¹	CIE-Y ¹	Power ²	Flux ²	Efficacy ²
0.5W	2700	46.98%	46.98%	3.02%	3.02%	70.5	70.5	4.5	4.5	0.4575	0.4098	0.431	52.33	121.5
	3000	36.36%	50.91%	6.36%	6.36%	54.5	76.4	9.5	9.5	0.4329	0.4022	0.430	54.02	125.6
	3500	27.47%	51.28%	10.62%	10.62%	41.2	76.9	15.9	15.9	0.4074	0.3915	0.427	55.55	130.1
	4000	19.30%	49.12%	15.79%	15.79%	28.9	73.7	23.7	23.7	0.3815	0.3792	0.425	57.00	134.1
	5000	14.29%	34.29%	25.71%	25.71%	21.4	51.4	38.6	38.6	0.3443	0.3541	0.419	58.37	139.2
	5700	14.47%	23.68%	30.92%	30.92%	21.7	35.5	46.4	46.4	0.3287	0.3411	0.418	58.49	140.0
	6500	14.17%	12.50%	36.67%	36.67%	21.3	18.8	55.0	55.0	0.3121	0.3278	0.419	58.34	139.3
1W	2700	47.58%	46.74%	2.84%	2.84%	142.7	140.2	8.5	8.5	0.4576	0.4095	0.922	98.43	106.7
	3000	36.18%	51.95%	5.94%	5.94%	108.5	155.8	17.8	17.8	0.4340	0.4030	0.920	102.21	111.2
	3500	27.10%	52.34%	10.28%	10.28%	81.3	157.0	30.8	30.8	0.4078	0.3919	0.908	105.76	116.4
	4000	18.85%	50.27%	15.44%	15.44%	56.6	150.8	46.3	46.3	0.3823	0.3799	0.899	109.02	121.2
	5000	12.91%	35.78%	25.65%	25.65%	38.7	107.3	77.0	77.0	0.3451	0.3559	0.883	112.50	127.5
	5700	13.04%	24.64%	31.16%	31.16%	39.1	73.9	93.5	93.5	0.3292	0.3428	0.883	112.69	127.6
	6500	13.48%	12.36%	37.08%	37.08%	40.4	37.1	111.2	111.2	0.3128	0.3290	0.892	111.94	125.5

Notes for Table 3:

1. Products tested at 1W for T_{sp} = 55°C.
2. The performance tested when T_j=T_{sp}+25°C.

Spectrum Characteristics

Table 4: Typical Color Rendering Index and TM-30 Values. $T_{sp}=55^{\circ}\text{C}$ ¹

Power	Nominal CCT ²	X	Y	CRI	Rf	Rg	R1	R2	R3	R4	R5	R6	R7	R8	R9	R10	R11	R12	R13	R14	R15
0.5W	2700	0.4575	0.4098	98	97	99	97	96	97	96	99	98	95	99	93	96	97	97	100	97	100
	3000	0.4329	0.4022	98	97	99	97	96	97	97	100	99	99	99	94	95	97	97	99	97	100
	3500	0.4074	0.3915	98	97	99	97	97	98	98	99	98	96	99	95	94	97	97	99	97	100
	4000	0.3815	0.3792	98	98	100	97	98	99	99	99	98	96	99	97	92	98	98	99	97	100
	5000	0.3443	0.3541	98	99	99	97	98	99	98	98	98	96	98	97	96	99	98	99	97	99
	5700	0.3287	0.3411	98	98	100	96	98	99	98	98	97	93	98	97	95	99	98	99	97	99
	6500	0.3121	0.3278	98	99	99	96	98	100	97	98	97	94	97	98	93	99	98	99	97	99
1W	2700	0.4576	0.4095	98	98	100	97	96	98	97	98	97	93	99	93	98	98	97	100	97	100
	3000	0.4340	0.4030	98	98	100	96	96	98	98	99	99	97	99	94	98	98	97	100	97	100
	3500	0.4078	0.3919	98	98	100	96	96	98	99	99	98	99	98	95	97	98	97	99	97	100
	4000	0.3823	0.3799	98	99	99	95	97	99	98	98	98	99	96	96	95	99	97	100	97	100
	5000	0.3451	0.3559	97	99	98	95	96	98	97	96	96	98	94	96	95	99	97	99	97	99
	5700	0.3292	0.3428	97	100	97	94	95	98	97	96	96	99	93	96	95	99	96	99	97	99
	6500	0.3128	0.3290	96	99	97	94	95	98	96	95	96	99	92	96	94	98	96	99	97	99

Figure 1: Chromaticity Coordinate Group (Color Targeted at $T_{sp}=55^{\circ}\text{C}$)

Note for Table 4:

1. Bridgelux maintains a tolerance of ± 3 on Color Rendering Index R1-R15 measurements and TM-30 measurements.
2. Rn reference by Nominal Drive Current will have deviations when changed drive current.

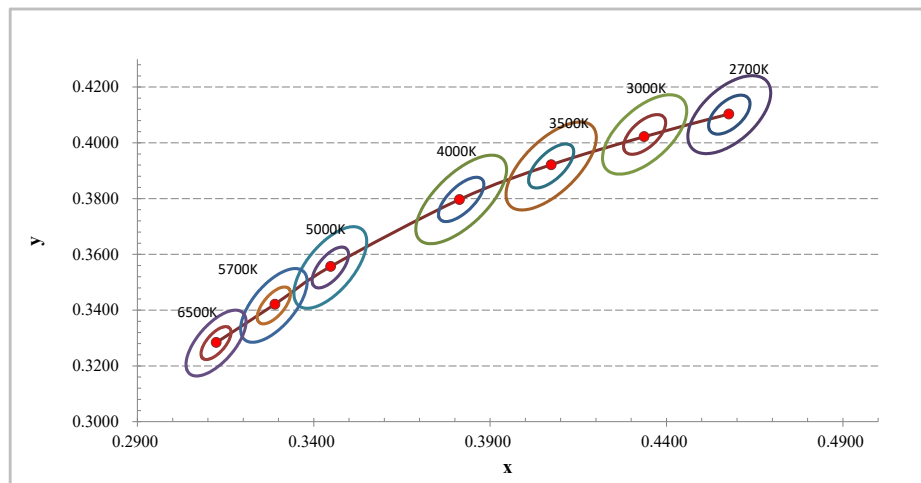

Spectrum Characteristics

Figure 2: Typical Color Spectrum

Note for Figure 2:

1. Color spectra measured reference by nominal current for $T_{sp} = 55^{\circ}\text{C}$.

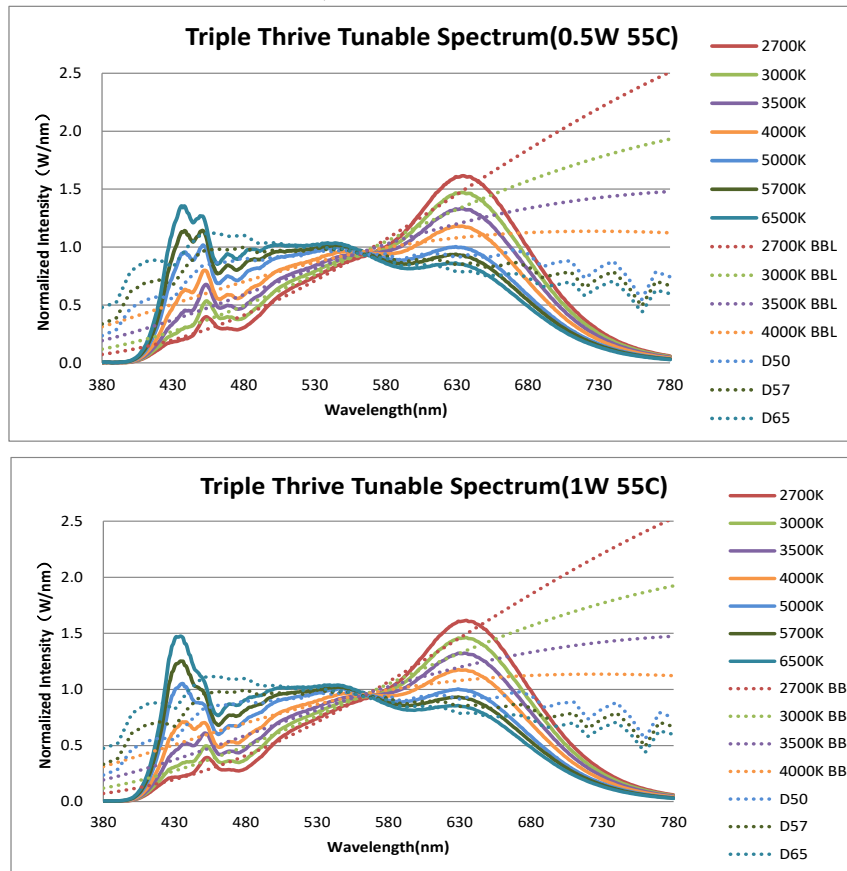

Spectral Matching to Natural Light

Humans have evolved and thrived for millions of years under the sun's natural daylight. While discussions continue regarding the development of LED products with artificial spectra aimed at increasing productivity and focus or helping with relaxation, the long-term physiological effects of such altered environments on humans remains unknown.

Bridgelux Thrive is engineered to provide the closest match to natural light using proprietary chip, phosphor and packaging technology. Bridgelux is working with our customers and industry partners to define new metrics to describe and quantify this spectral matching: going beyond today's quality of light metrics such as CRI and TM-30.

Spectrum Characteristics

Figure 3: 0.5W 2700K Thrive TM-30 Graphs

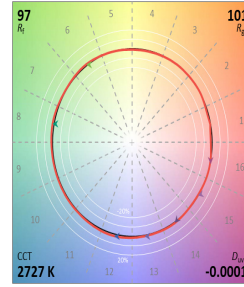
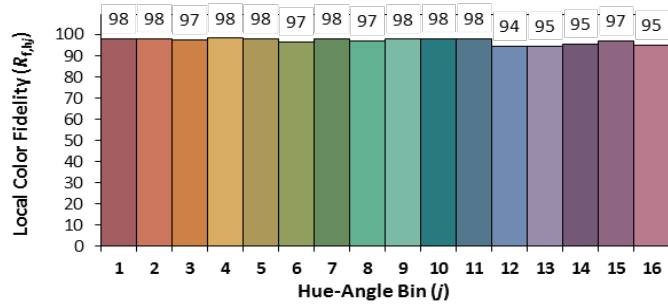

Figure 4: 0.5W 3000K Thrive TM-30 Graphs

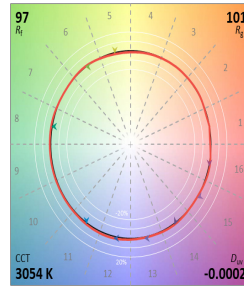
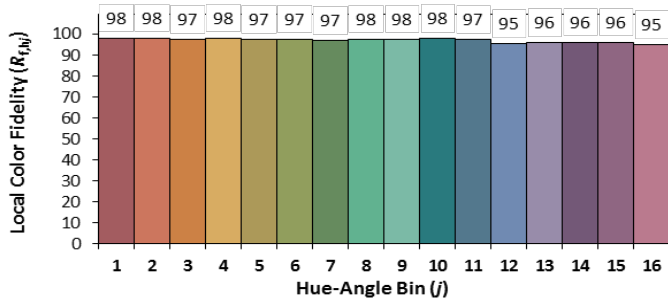

Figure 5: 0.5W 3500K Thrive TM-30 Graphs

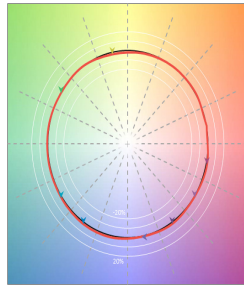
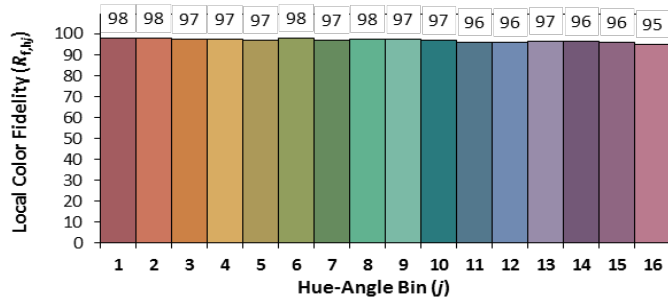
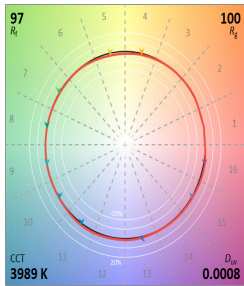
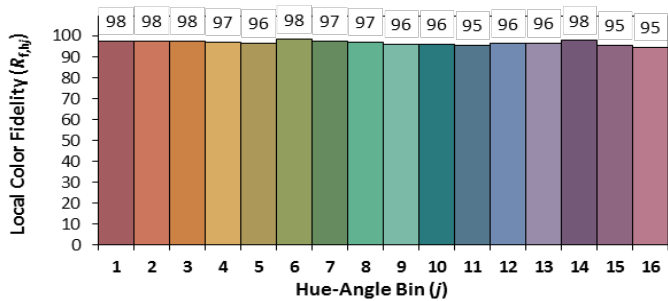

Figure 6: 0.5W 4000K Thrive TM-30 Graphs



Spectrum Characteristics

Figure 7: 0.5W 5000K Thrive TM-30 Graphs

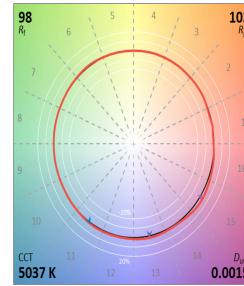
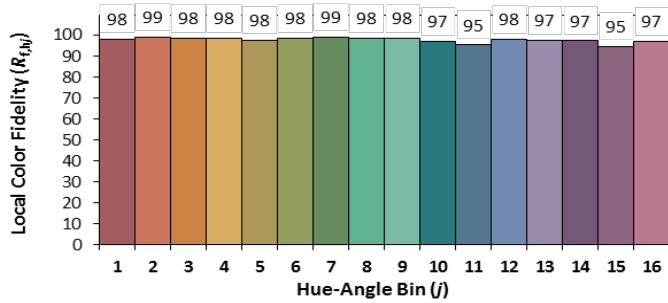

Figure 8: 0.5W 5700K Thrive TM-30 Graphs

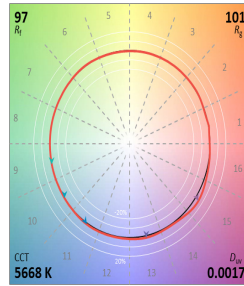
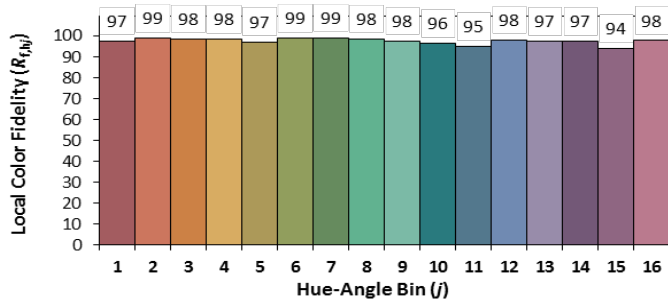
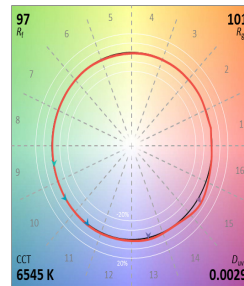
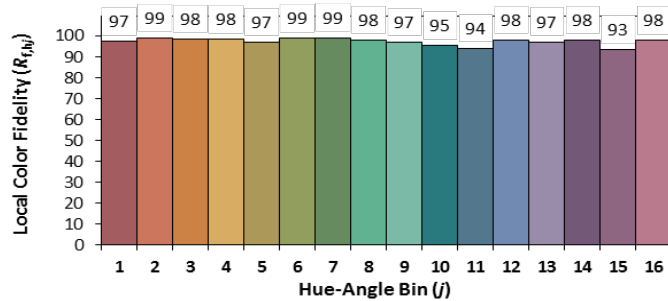

Figure 9: 0.5W 6500K Thrive TM-30 Graphs



Spectrum Characteristics

Figure 10: 1W 2700K Thrive TM-30 Graphs

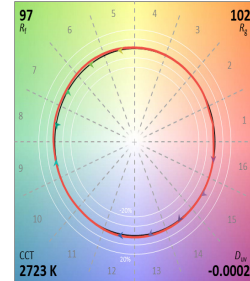
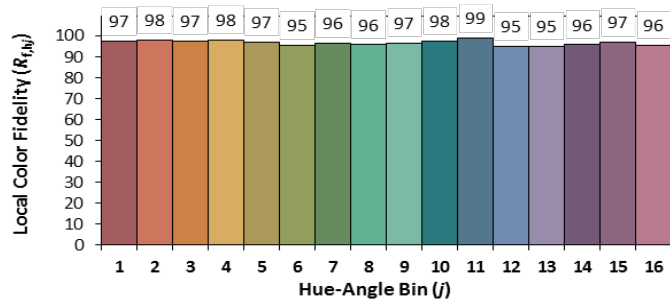

Figure 11: 1W 3000K Thrive TM-30 Graphs

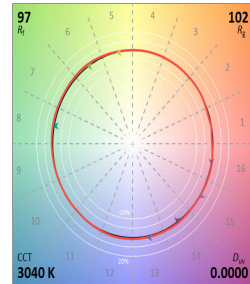
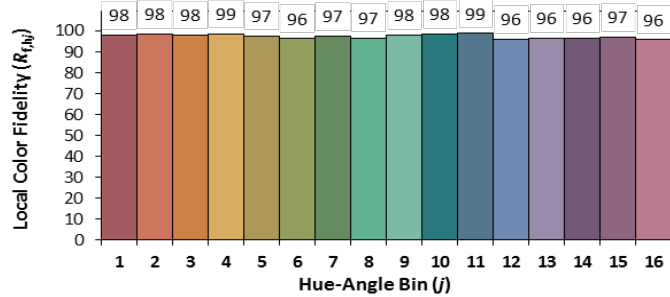

Figure 12: 1W 3500K Thrive TM-30 Graphs

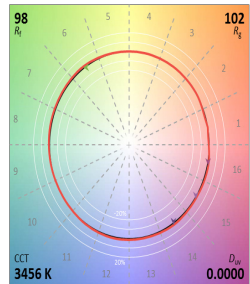
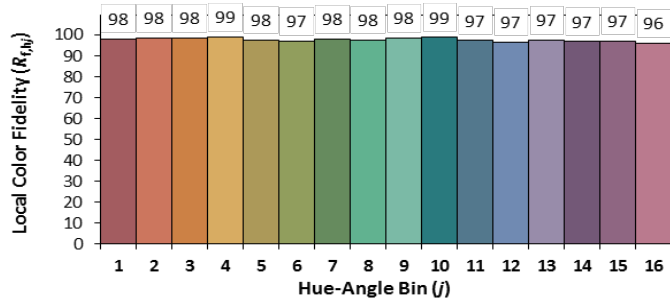
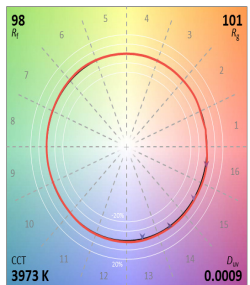
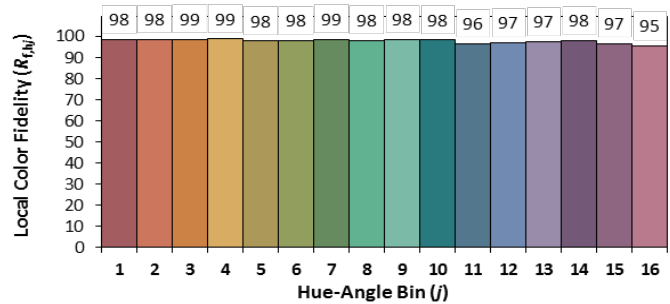

Figure 13: 1W 4000K Thrive TM-30 Graphs



Spectrum Characteristics

Figure 14: 1W 5000K Thrive TM-30 Graphs

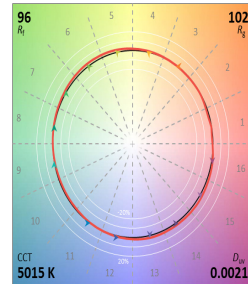
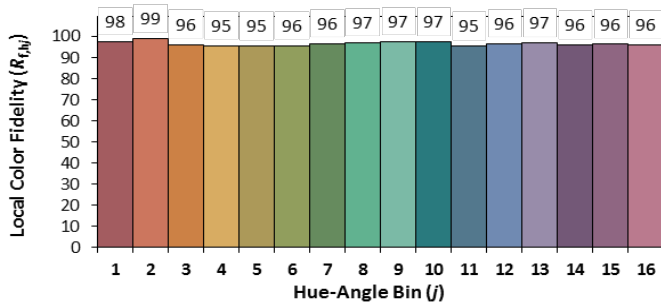

Figure 15: 1W 5700K Thrive TM-30 Graphs

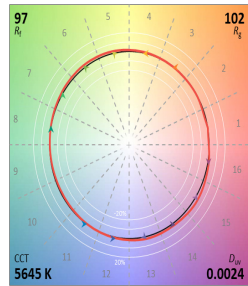
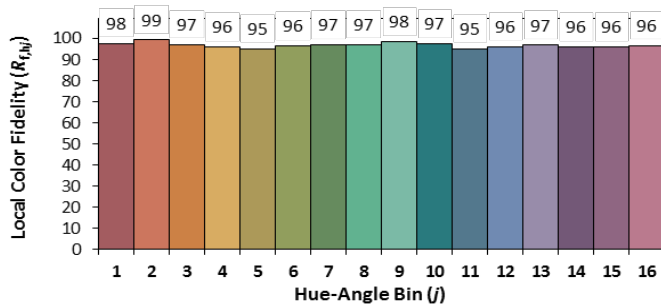
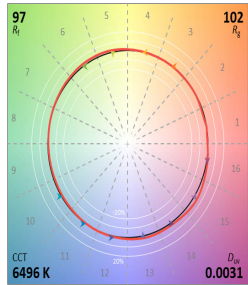
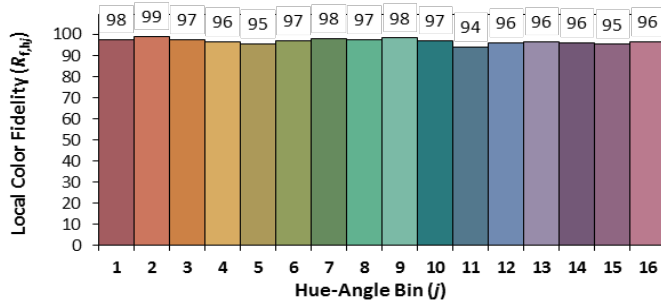

Figure 16: 1W 6500K Thrive TM-30 Graphs



Absolute Maximum Ratings

Table 5: Maximum Ratings

Parameter	Maximum Rating		
LED Junction Temperature (T_j)	125°C		
Storage Temperature	-40°C to +105°C		
Operating Solder Point Temperature (T_{sp})	-40°C to +105°C		
Soldering Temperature	260°C or lower for a maximum of 10 seconds		
	C1	C2	C3
Maximum Drive Current (Single Color Light)	160mA	160mA	160mA
Peak Pulsed Forward Current ¹	200mA	200mA	200mA
Maximum Power	1W		
Maximum Reverse Voltage ²	-5V		
Moisture Sensitivity Rating	MSL 3		
Electrostatic Discharge	2kV HBM. JEDEC-JS-001-HBM and JEDEC-JS-001-2012		

Notes for Table 5:

1. Bridgelux recommends a maximum duty cycle of 10% and pulse width of 10 ms when operating LED SMD at maximum peak pulsed current specified. Maximum peak pulsed current indicate values where LED SMD can be driven without catastrophic failures.
2. Light emitting diodes are not designed to be driven in reverse voltage and will not produce light under this condition. Maximum rating provided for reference only.

Product Bin Definitions

Table 6: MacAdam Ellipse Color Bin Definitions

CCT	Center Point		Major Axis	Minor Axis	Ellipse Rotation Angle	Color Bin
	X	Y				
C1	0.5146	0.3884	0.0135	0.0070	18°	5
C2	0.4454	0.4545	0.0135	0.0070	35°	3/A/B
C3 ³	0.2729	0.3065	0.0135	0.0070	70°	3/A/B

Notes for Table 6:

1. Color binning at $T_{sp} = 25^{\circ}\text{C}$ unless otherwise specified
2. Bridgelux maintains a tolerance of ± 0.007 on x and y color coordinates.
3. The performance is based on both C3 lighting up simultaneously in parallel.

Figure 17: Chromaticity Coordinate Group (Color Bin Structure, Color Targeted at $T_{sp} = 25^{\circ}\text{C}$)

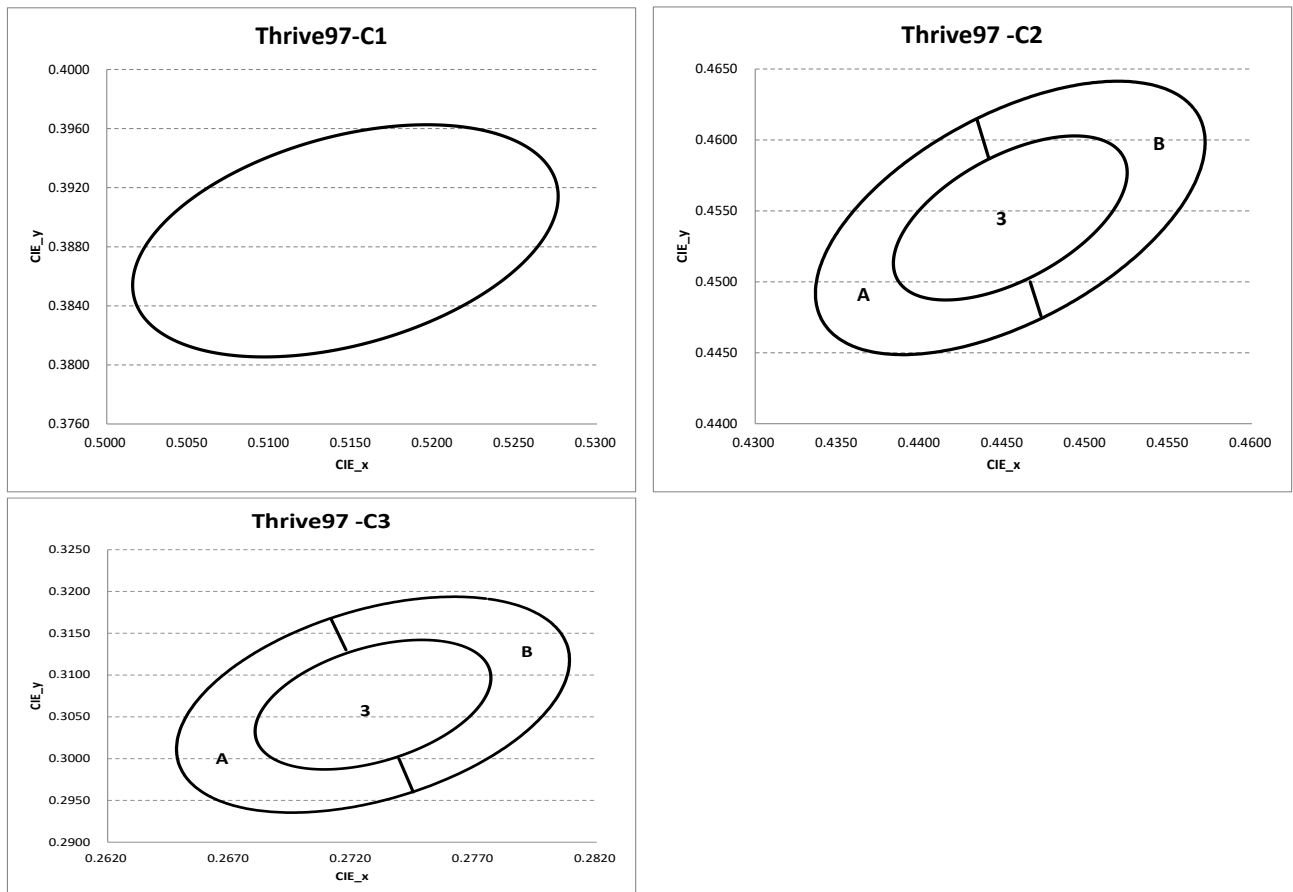

Notes for Figure 1:

1. The performance is based on both C3 lighting up simultaneously in parallel.

Product Bin Definitions

Table 7 lists the standard photometric luminous flux bins for SMD 3838 Triple CCT Thrive97. Although several bins are outlined, product availability in a particular bin varies by production run and by product performance.

Table 7: Luminous Flux Range Definitions at 60mA, $T_{sp}=25^{\circ}\text{C}$

Color	Luminous Flux ¹		Unit	Condition
	Minimum	Maximum		
C1	16.4	19	lm	$I_F=60\text{mA}$
C2	22	25		
C3 ²	23	26.5		

Note for Table 7:

1. Bridgelux maintains a tolerance of $\pm 7.5\%$ on luminous flux measurements.
2. The luminous flux (lm) is based on both C3 lighting up simultaneously in parallel.
3. No flux bin.

Table 8: Forward Voltage Range Definitions at 60mA, $T_{sp}=25^{\circ}\text{C}$

Color	Forward Voltage ¹		Unit	Condition
	Minimum	Maximum		
C1/C2/C3	2.8	3.2	V	$I_F=60\text{mA}$

Note for Table 8:

1. Bridgelux maintains a tolerance of $\pm 0.1\text{V}$ on forward voltage measurements.
2. No vf bin.

Table 9: Color Bin in combination at 60mA

Bin Code	Color Bin		
	C1	C2	C3
S01	5	3	3
S02	5	3	A
S03	5	3	B
S04	5	A	3
S05	5	A	A
S06	5	A	B
S07	5	B	3
S08	5	B	A
S09	5	B	B

Note for Table 9:

The bin combination is as follows:

1. Bin S01 can be used independently.
2. The bin code used 2:1 combination of S05+S09 (2*S05+S09)
3. Other bin codes used in 1:1 combinations of S01+S02, S02+S06, S03+S05, S04+S08, S05+S07.

Performance Curves

Figure 18: Drive Current vs. Voltage ($T_{sp}=25^{\circ}\text{C}$)

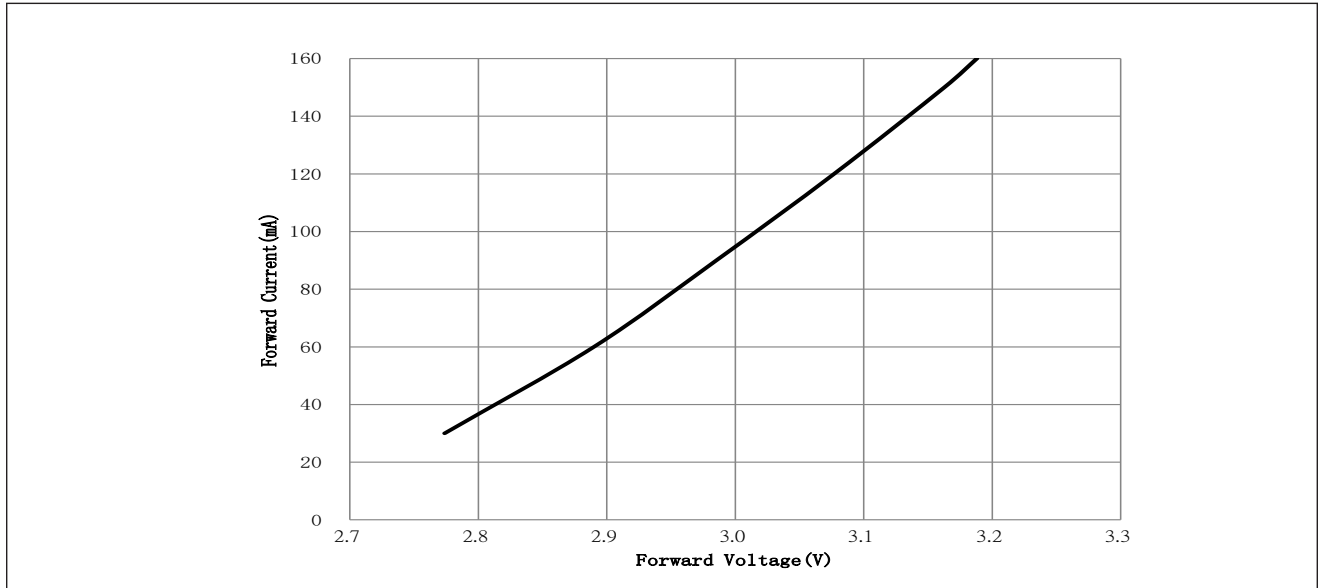
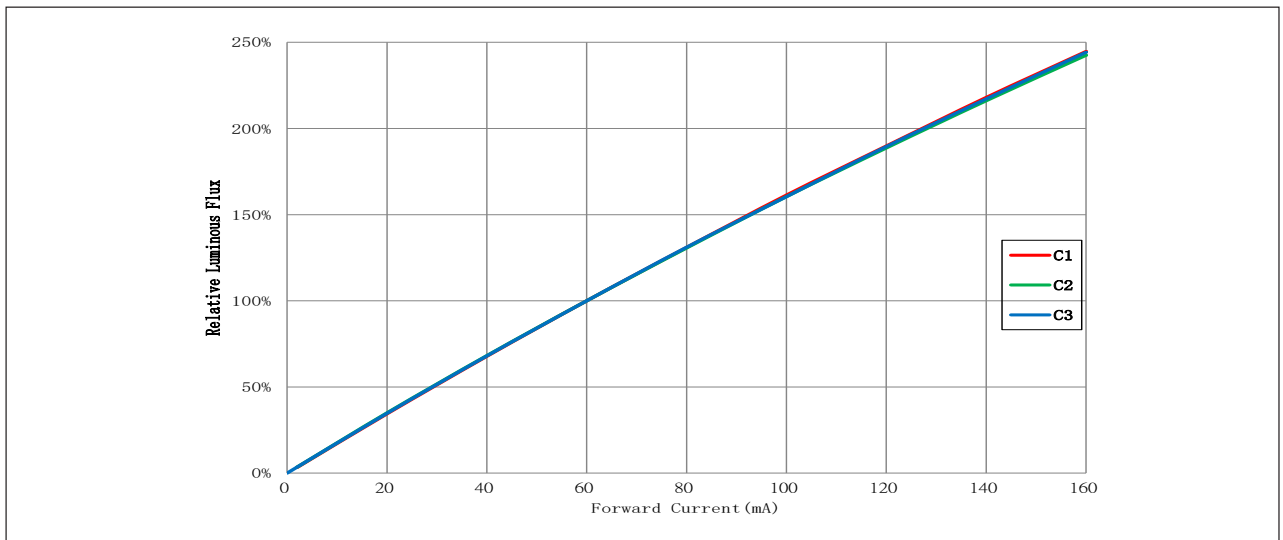

Figure 19: Typical Relative Luminous Flux vs. Drive Current ($T_{sp}=25^{\circ}\text{C}$)



Note for Figure 12:

1. Pulse width modulation (PWM) is recommended for dimming effects.

Performance Curves

Figure 20: Typical Relative Flux vs. Solder Point Temperature

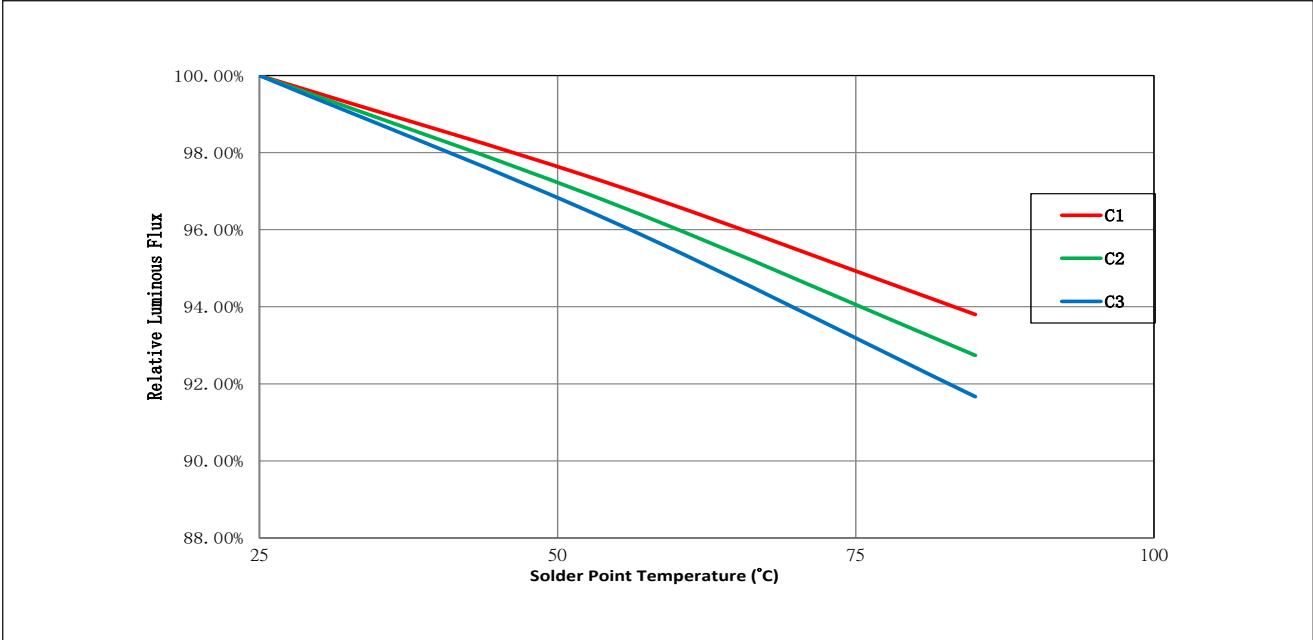

Typical Radiation Pattern

Figure 21: Typical Spatial Radiation Pattern at 60mA, $T_{sp}=25^{\circ}\text{C}$

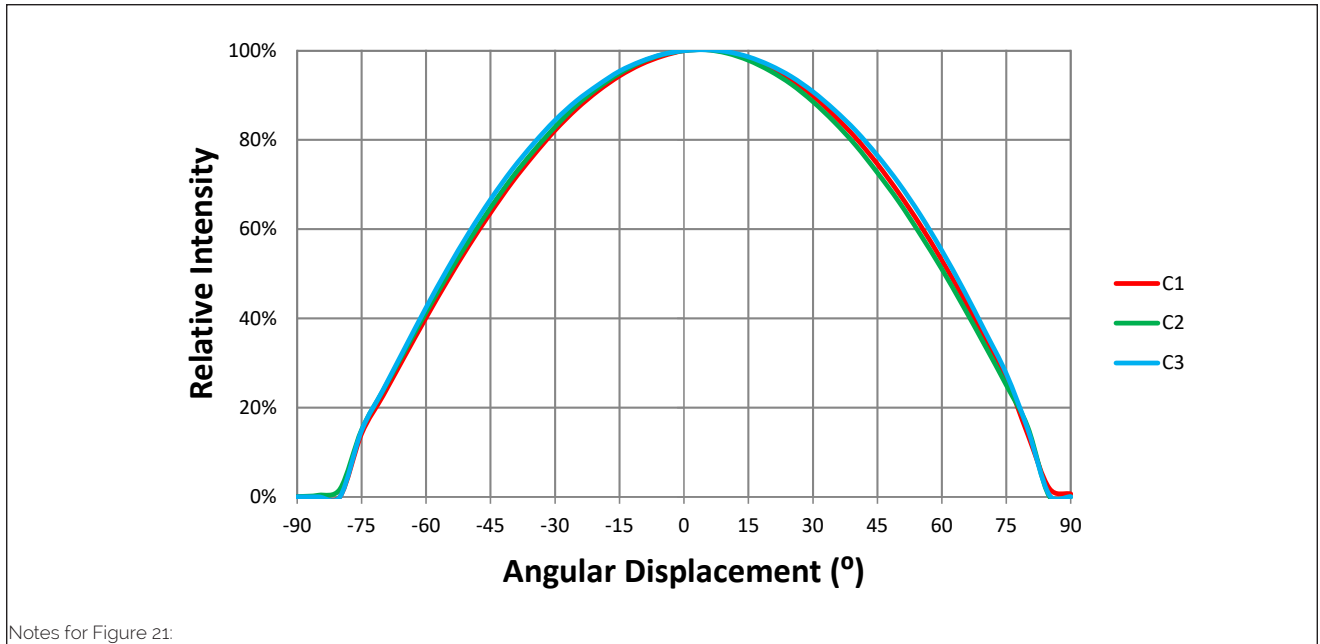
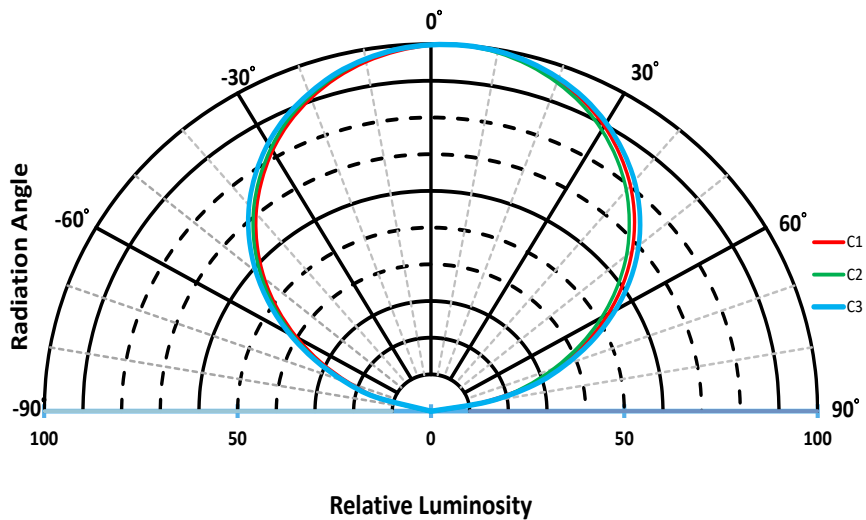
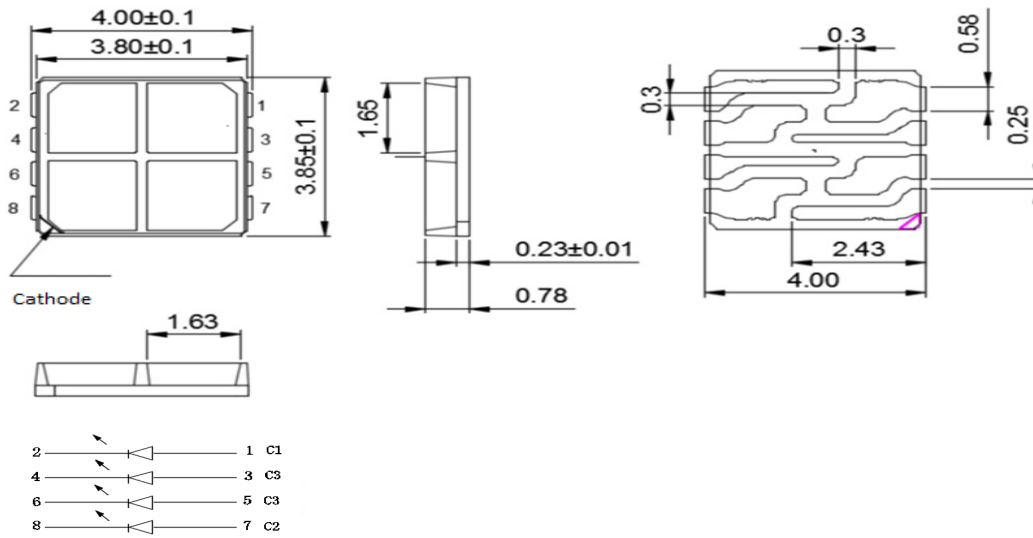

Figure 22: Typical Polar Radiation Pattern at 60mA, $T_{sp}=25^{\circ}\text{C}$



Mechanical Dimensions

Figure 23: Drawing for SMD 3838



Notes for Figure 23:

1. Drawings are not to scale.
2. Drawing dimensions are in millimeters.
3. Unless otherwise specified, tolerances are ± 0.10 mm.
4. The optical center of the LED emitter is nominally defined by the mechanical center of the emitter. The light emitting surface (LES) is centered on the mechanical center of the LED emitter to a tolerance of ± 0.2 mm

Recommended PCB Soldering Pad Pattern

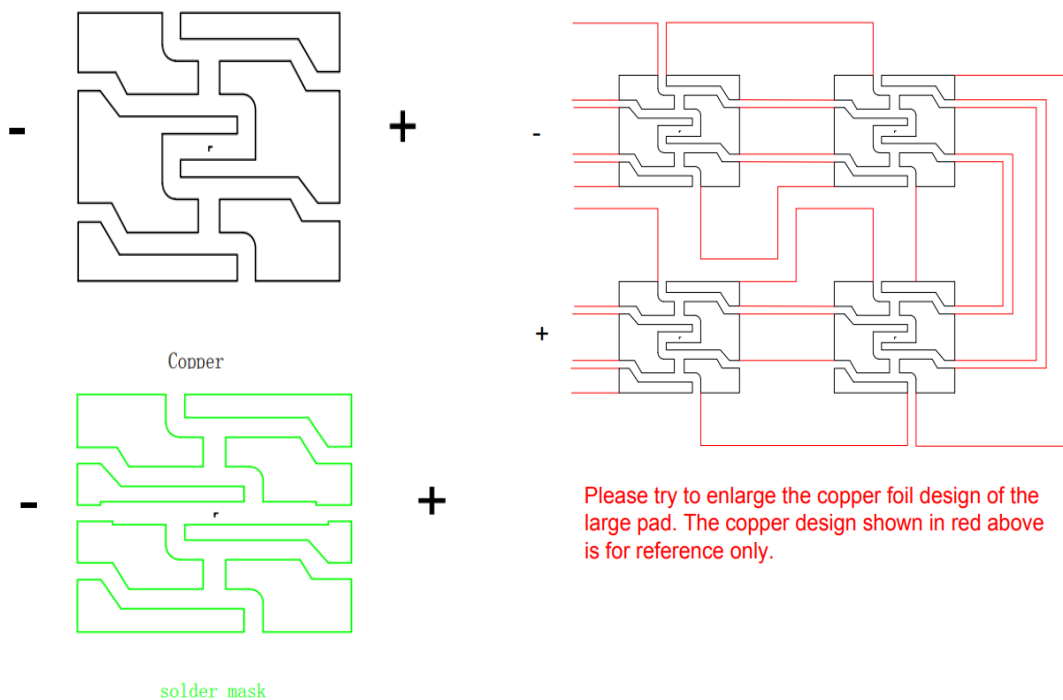

Reliability

Table 10: Reliability Test Items and Conditions

No.	Items	Reference Standard	Test Conditions	Drive Current	Test Duration	Units Failed/Tested
1	Moisture Sensitivity Level	J-STD-020D1	$T_{\text{std}} = 260^{\circ}\text{C}$, 10sec. Precondition: 85°C , 60%RH, 168hr		3 reflows	0/22
2	Low Temperature Storage	JESD22-A119	$T_{\text{a}} = -40^{\circ}\text{C}$		1000 hours	0/22
3	High Temperature Storage	JESD22-A103	$T_{\text{a}} = 105^{\circ}\text{C}$		1000 hours	0/22
4	Low Temperature Operating Life	JESD22-A108	$T_{\text{a}} = -40^{\circ}\text{C}$	60mA	1000 hours	0/22
5	Temperature Humidity Operating Life	JESD22-A101	$T_{\text{sp}} = 85^{\circ}\text{C}$, RH=85%	60mA	1000 hours	0/22
6	High Temperature Operating Life	JESD22-A108	$T_{\text{sp}} = 105^{\circ}\text{C}$, 4 channel all on	total 300mA	1000 hours	0/22
7	Thermal Shock	JESD22-A104	$T_{\text{a}} = -40^{\circ}\text{C} \sim 100^{\circ}\text{C}$, Dwell : 15min; Transfer: 10sec		200 Cycles	0/22
8	Temperature Cycle	JESD22-A104	$T_{\text{a}} = -40^{\circ}\text{C} \sim 100^{\circ}\text{C}$, Dwell at extreme temperature: 15min; Ramp rate < $105^{\circ}\text{C}/\text{min}$		200 Cycles	0/22

Passing Criteria

Item	Symbol	Test Condition	Passing Criteria
Forward Voltage	Vf	60mA	$\Delta V_f < 10\%$
Luminous Flux	Iv	60mA	$\Delta I_v < 30\%$
Chromaticity Coordinates	(x, y)	60mA	$\Delta u'v' < 0.007$

Notes for Table 10:

- Measurements are performed after allowing the LEDs to return to room temperature
- T_{std} : reflow soldering temperature; T_{a} : ambient temperature.

Reflowing Characteristics

Figure 24 : Reflow Profile

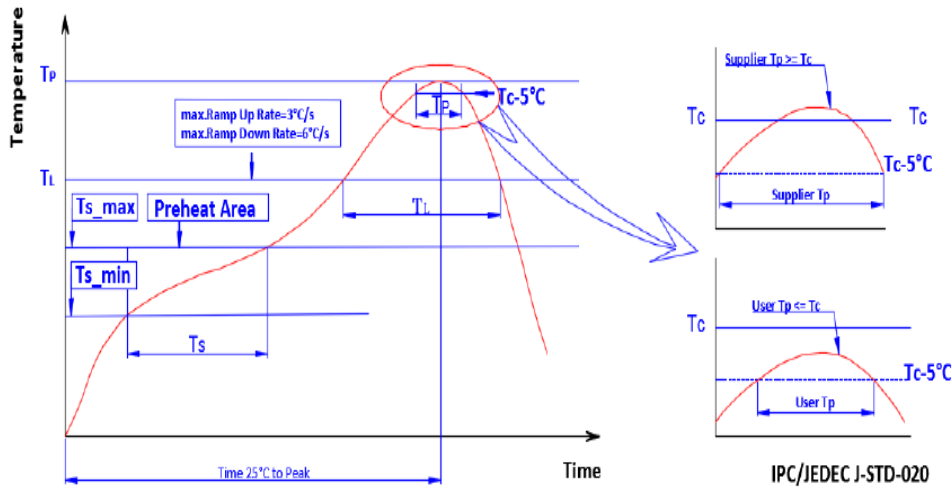

Profile Feature	Lead Free Assembly
Temperature Min. (T_{s_min})	160°C
Temperature Max. (T_{s_max})	205°C
Time (ts) from T_{s_min} to T_{s_max}	60-150 seconds
Ramp-Up Rate (TL to T_p)	3 °C/second
Liquidus Temperature (TL)	220 °C
Time (TL) Maintained Above TL	60-150 seconds
Peak Temp (T_p)	260 °C max.
Time (T_p) Within 5 °C of the Specified Classification Temperature (T_c)	25 seconds max.
Ramp-Down Rate (T_p to TL)	5 °C/second max.
Time 25 °C to Peak Temperature	10 minutes max.

Packaging

Figure 25: Emitter Reel Drawings

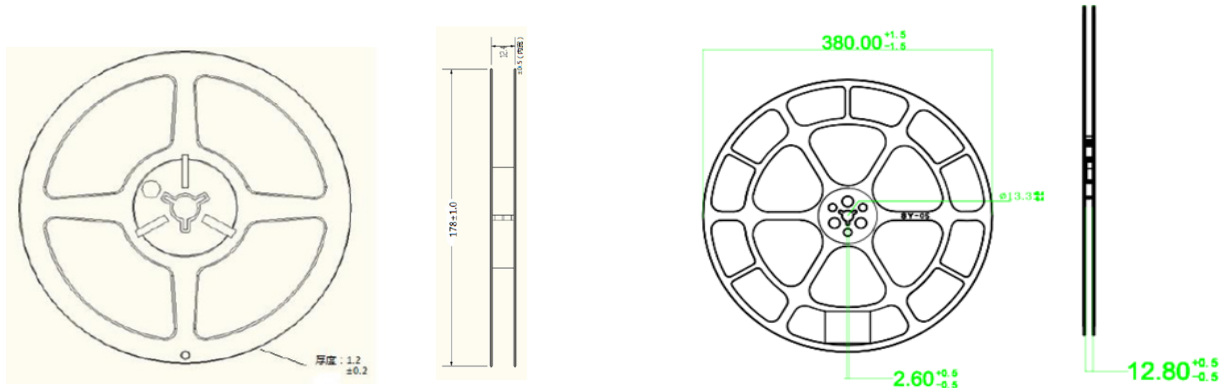

Note for Figure 18:

1. Drawings are not to scale. Drawing dimensions are in millimeters.

Figure 26: Emitter Tape Drawings

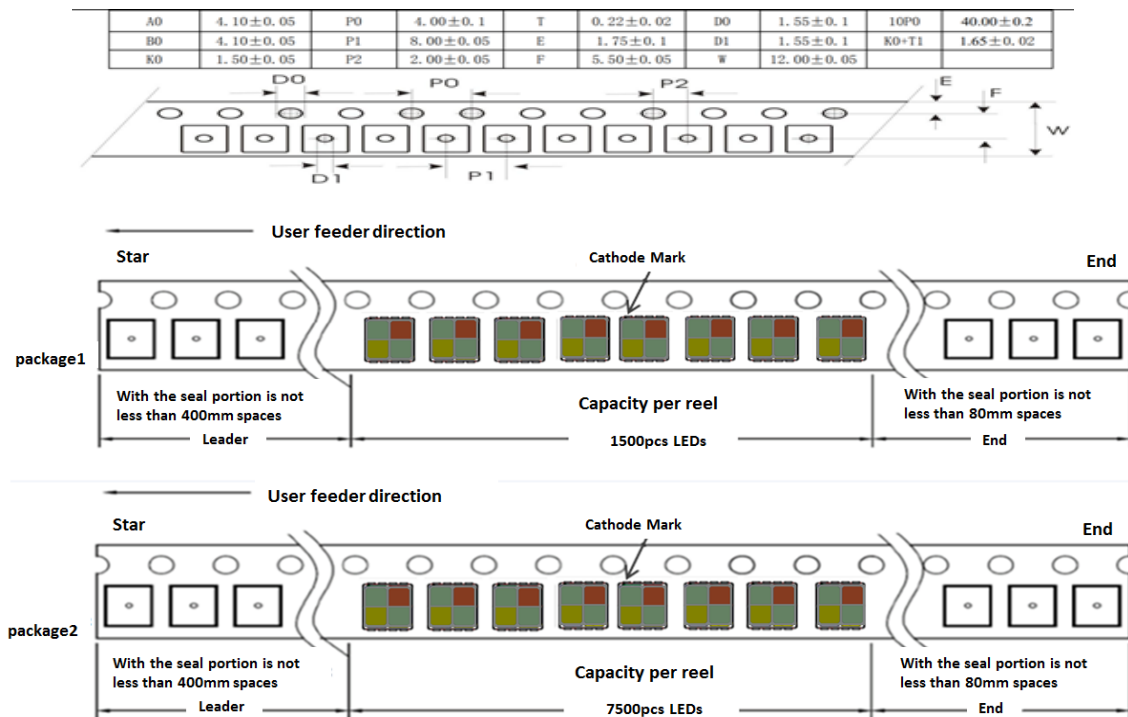

Note for Figure 19:

1. Drawings are not to scale. Drawing dimensions are in millimeters.

Packaging

Figure 27: Emitter Reel Packaging Drawings

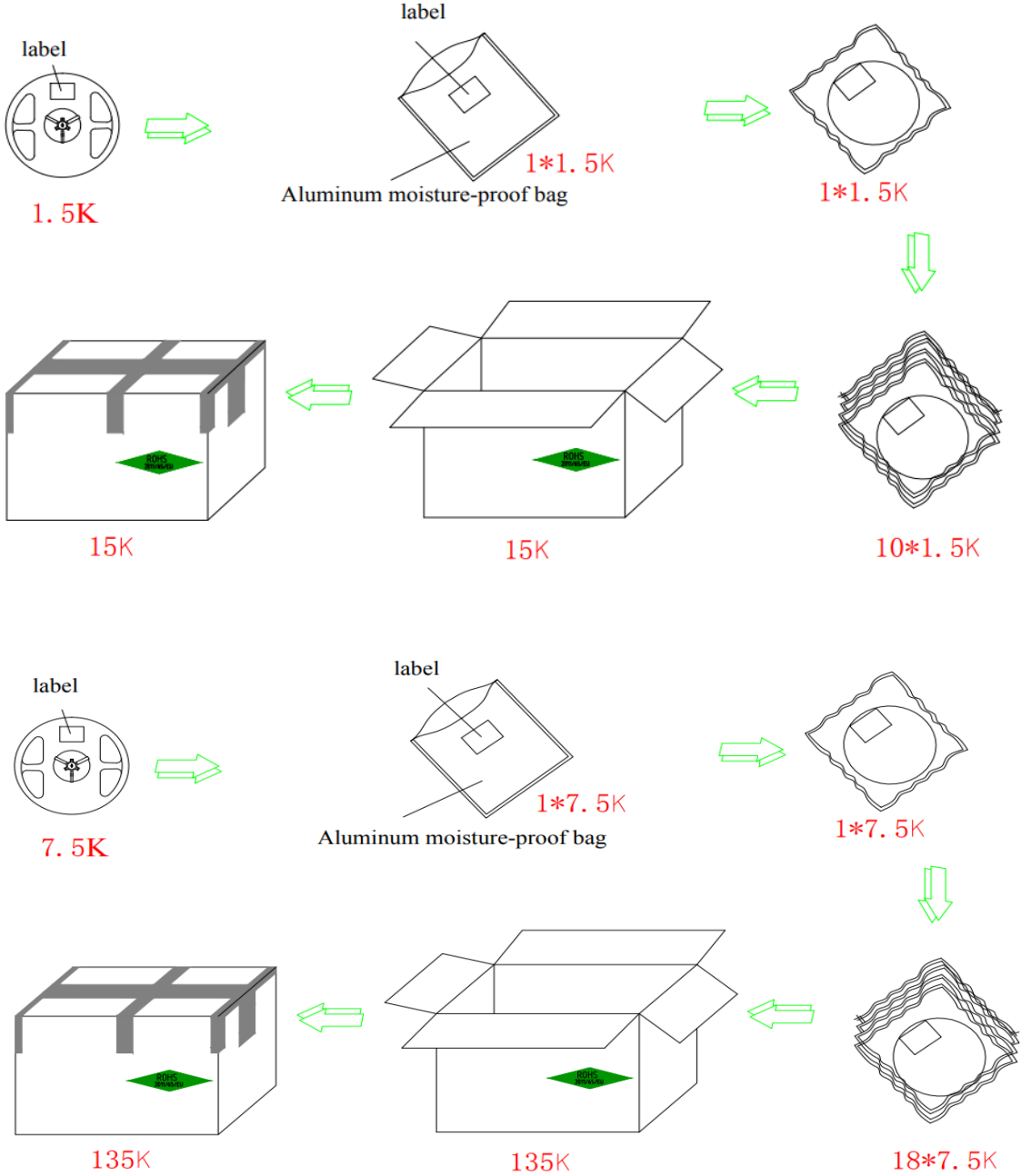

Note for Figure 27:
 1. Drawings are not to scale.

Design Resources

Please contact your Bridgelux sales representative for assistance.

Precautions

CAUTION: CHEMICAL EXPOSURE HAZARD

Exposure to some chemicals commonly used in luminaire manufacturing and assembly can cause damage to the LED emitter. Please consult Bridgelux Application Note AN51 for additional information.

CAUTION: EYE SAFETY

Eye safety classification for the use of Bridgelux SMD LED emitter is in accordance with IEC specification EN62471: Photobiological Safety of Lamps and Lamp Systems. SMD LED emitters are classified as Risk Group 1 when operated at or below the maximum drive current. Please use appropriate precautions. It is important that employees working with LEDs are trained to use them safely.

CAUTION: RISK OF BURN

Do not touch the SMD LED emitter during operation. Allow the emitter to cool for a sufficient period of time before handling. The SMD LED emitter may reach elevated temperatures such that could burn skin when touched.

CAUTION

CONTACT WITH LIGHT EMITTING SURFACE (LES)

Avoid any contact with the LES. Do not touch the LES of the emitter or apply stress to the LES (yellow phosphor resin area). Contact may cause damage to the emitter

Optics and reflectors must not be mounted in contact with the LES (yellow phosphor resin area).

Disclaimers

MINOR PRODUCT CHANGE POLICY

The rigorous qualification testing on products offered by Bridgelux provides performance assurance. Slight cosmetic changes that do not affect form, fit, or function may occur as Bridgelux continues product optimization.

STANDARD TEST CONDITIONS

Unless otherwise stated, LED emitter testing is performed at the nominal drive current.

About Bridgelux: Bridging Light and Life™

At Bridgelux, we help companies, industries and people experience the power and possibility of light. Since 2002, we've designed LED solutions that are high performing, energy efficient, cost effective and easy to integrate. Our focus is on light's impact on human behavior, delivering products that create better environments, experiences and returns—both experiential and financial. And our patented technology drives new platforms for commercial and industrial luminaires.

For more information about the company, please visit
bridgelux.com
twitter.com/Bridgelux
facebook.com/Bridgelux
youtube.com/user/Bridgelux
WeChat ID: BridgeluxInChina
https://www.linkedin.com/company/bridgelux-inc-_2



46410 Fremont Boulevard
Fremont, CA 94538 USA
Tel (925) 583-8400
Fax (925) 583-8401
www.bridgelux.com

© 2025 Bridgelux, Inc. All rights reserved 2020. Product specifications are subject to change without notice. Bridgelux and the Bridgelux stylized logo design are registered trademarks of Bridgelux, Inc. All other trademarks are the property of their respective owners.