

100V 52A N-Channel Enhancement Mode Power MOSFET

Features

- $R_{DS(on)} \leq 13m\Omega$ @ $V_{gs}=10V$
- Advanced SGT process
- Excellent $R_{DS(on)}$ and Low Gate Charge
- Lead free product is acquired

Application

- High Frequency Switching
- Synchronous Rectification

SYMBOL

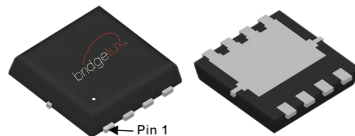
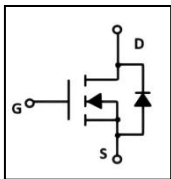

PDFN5*6

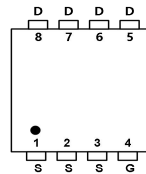

ASSEMBLY MESSAGE

Product Name	Package	Packaging
BXS130N10C	PDFN5*6	Reel

ABSOLUTE MAXIMUM RATINGS ($T_C=25^\circ C$ unless otherwise noted)

Parameter		Symbol	Rating	Unit
			PDFN5*6	
Drain-Source Voltage		V_{DSS}	100	V
Drain Current	Continuous ($T_C = 25^\circ C$)	I_D	52	A
	Continuous ($T_C = 100^\circ C$)		33	A
Drain Current	Pulsed (Note1)	I_{DM}	208	A
Single Pulsed Avalanche Energy		EAS	48	mJ
Gate-Source Voltage		V_{GSS}	± 20	V
Power Dissipation	$T_C = 25^\circ C$	P_D	57	W
Maximum Junction Temperature		T_J	150	$^\circ C$
Storage Temperature Range		T_{STG}	-55 to 150	$^\circ C$

Note: 1. Repetitive Rating: Pulse width limited by maximum junction temperature

THERMAL CHARACTERISTICS

Parameter	Symbol	Max.	Unit
		PDFN5*6	
Thermal Resistance, Junction to Case	$R_{\theta JC}$	2.2	$^\circ C / W$

ELECTRICAL CHARACTERISTICS ($T_J=25^{\circ}\text{C}$, unless otherwise Noted)

Parameter	Symbol	Test Condition	Min.	Typ.	Max.	Unit
OFF CHARACTERISTICS						
Drain-Source Breakdown Voltage	BV_{DSS}	$V_{GS}=0V, I_D=250\mu A$	100			V
Zero Gate Voltage Drain Current	I_{DSS}	$V_{DS}=80V, V_{GS}=0V$			1	μA
Gate-Body Leakage Current, Forward	I_{GSS}	$V_{GS}=20V$			100	nA
Gate-Body Leakage Current, Reverse		$V_{GS}=-20V$			-100	nA
ON CHARACTERISTICS						
Gate Threshold Voltage	$V_{GS(TH)}$	$V_{DS}=V_{GS}, I_D=250\mu A$	1.2	1.8	2.6	V
Drain-Source On-State Resistance	$R_{DS(ON)}$	$V_{GS}=10V, I_D=20A$		10.5	13	$m\Omega$
		$V_{GS}=4.5V, I_D=10A$		14.5	17	$m\Omega$
DYNAMIC PARAMETERS						
Input Capacitance	C_{ISS}	$V_{DS}=50V, V_{GS}=0V,$ $f=1.0MHz$		1782		μF
Output Capacitance	C_{OSS}			251		μF
Reverse Transfer Capacitance	C_{RSS}			23		μF
SWITCHING PARAMETERS						
Turn-ON Delay Time	$t_{D(ON)}$	$V_{DD}=50V, I_D=20A, V_{GS}$ $= 10V, R_G=3\Omega$		35		ns
Turn-ON Rise Time	t_R			19		ns
Turn-OFF Delay Time	$t_{D(OFF)}$			33		ns
Turn-OFF Fall-Time	t_F			11		ns
Total Gate Charge(Note2)	Q_G	$V_{DS}=50V, V_{GS}=10V,$ $I_D=20A$		35		nC
Gate Source Charge	Q_{GS}			8		nC
Gate Drain Charge	Q_{GD}			9.5		nC
SOURCE- DRAIN DIODE RATINGS AND CHARACTERISTICS						
Drain-Source Diode Forward Voltage	V_{SD}	$I_S=20A, V_{GS}=0V$			1.4	V
Diode Continuous Forward Current	I_S				52	A
Maximum Pulsed Drain to Source Diode Forward Current	I_{SM}				208	A
Reverse Recovery Time	t_{rr}	$I_F=20A,$ $di/dt=100A/\mu s$		42		ns
Reverse Recovery Charge	Q_{rr}			52		nC

Note: 2. Essentially independent of operating temperature

TYPICAL CHARACTERISTICS

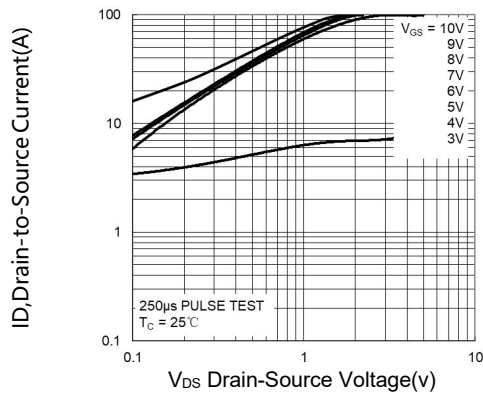

Figure1. Typical Output Characteristics

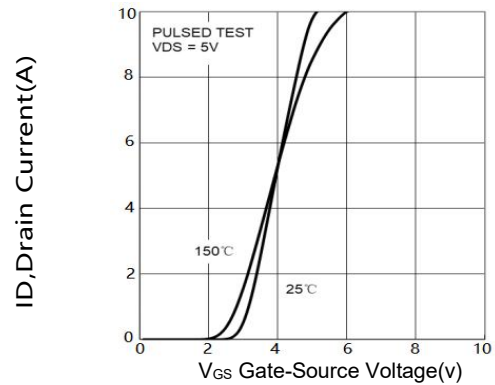

Figure2. Typical Transfer Characteristics

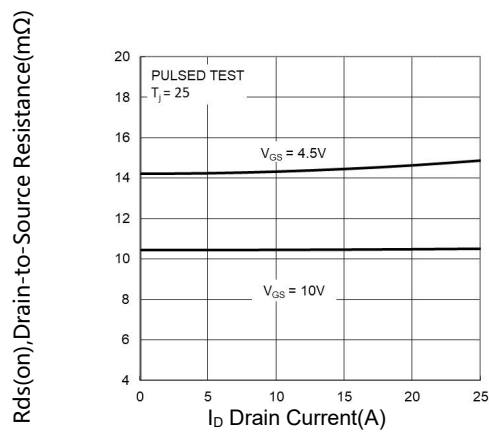

Figure3. On-Resistance versus Drain Current

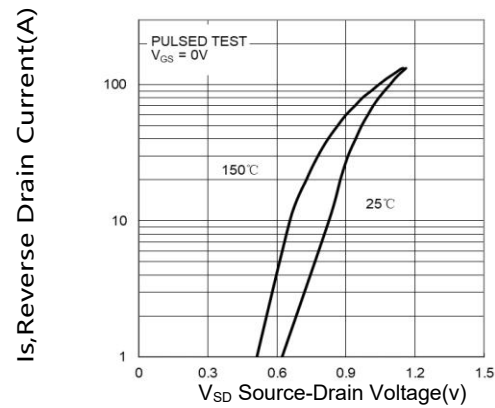

Figure4. Diode forward voltage versus Current

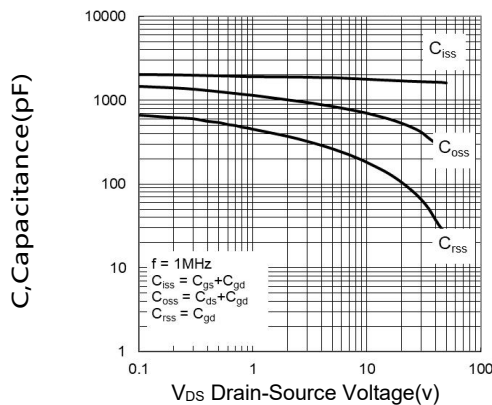

Figure5. Typical Capacitance versus V_{DS}

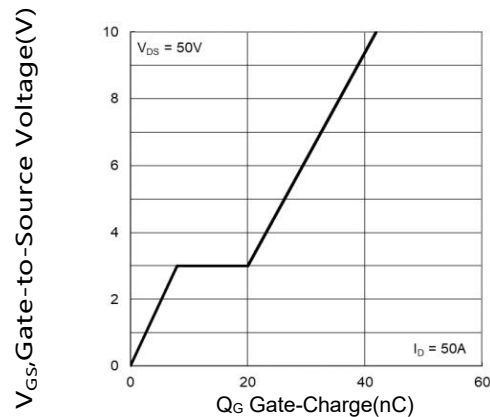

Figure6. Typical Gate Charge versus V_{GS}

TYPICAL CHARACTERISTICS(Cont.)

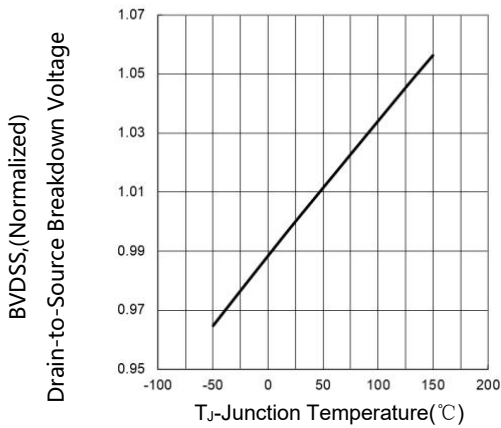

Figure7. BV_{DSS} Variation with Temperature

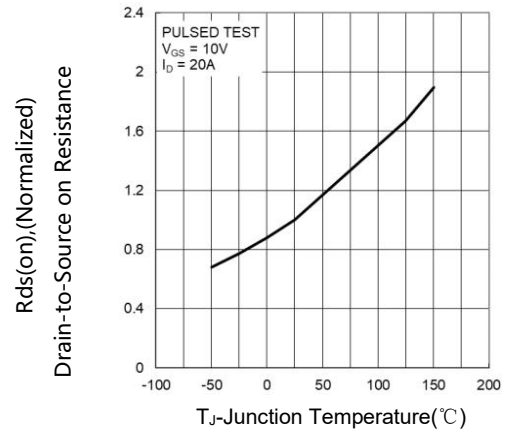

Figure8. On-Resistance Variation with Temperature

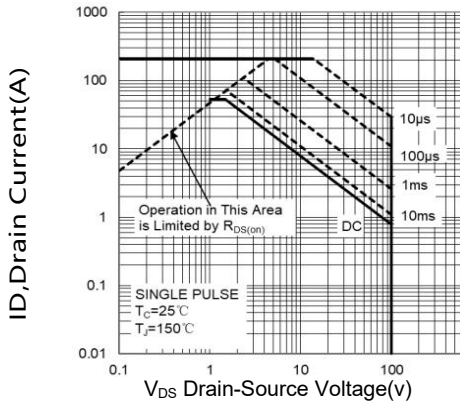

Figure9. Maximum Safe Operating Area

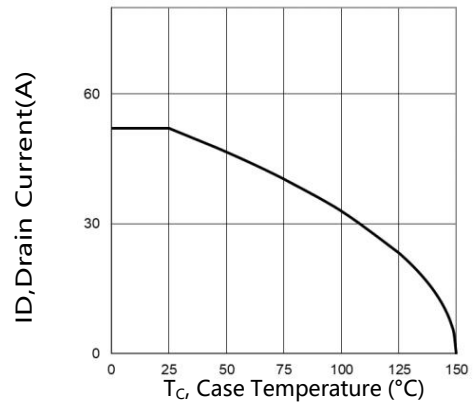
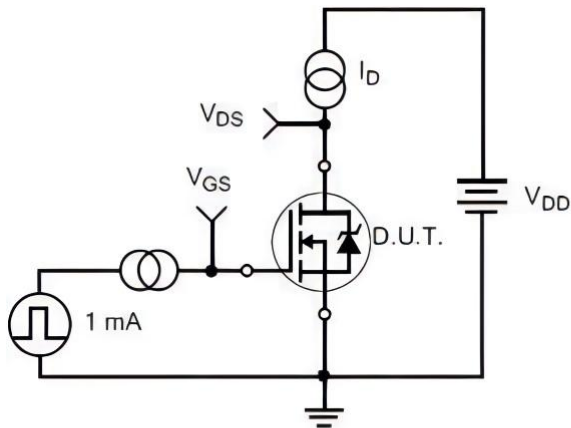
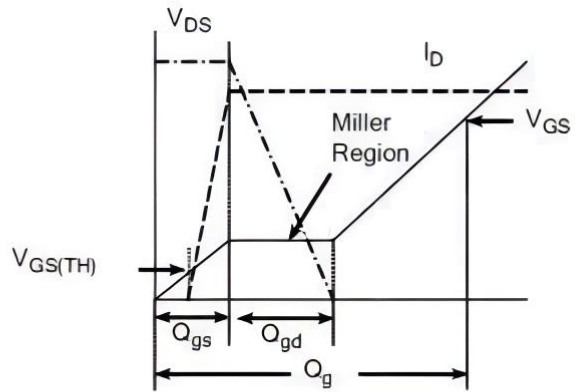

Figure10. Maximum Continuous Drain Current versus Case Temperature

TEST CIRCUITS AND WAVEFORMS



Gate Charge Test Circuit



Gate Charge Waveform

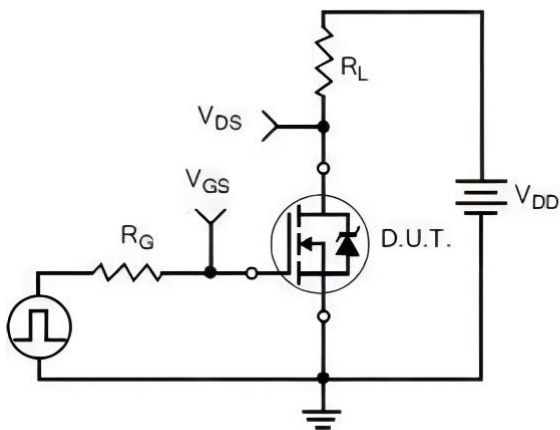

Resistive Switching Test Circuit

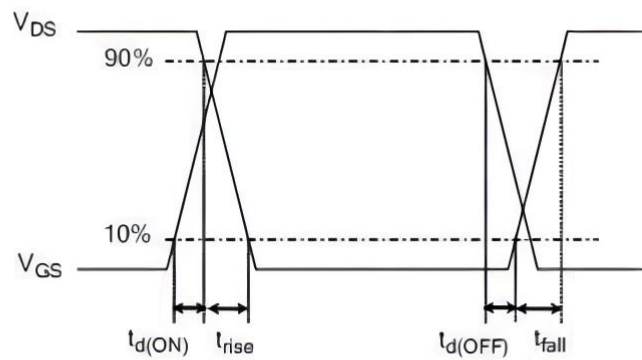

Resistive Switching Waveforms

TEST CIRCUITS AND WAVEFORMS(Cont.)

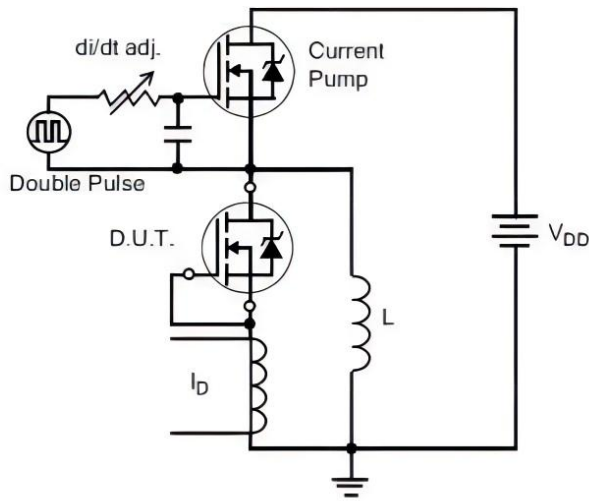

Diode Reverse Recovery Test Circuit

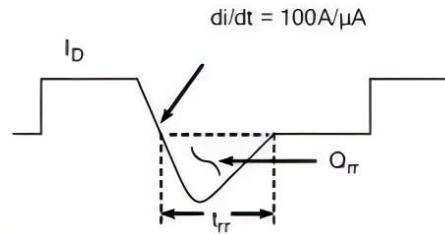

Diode Reverse Recovery Waveform

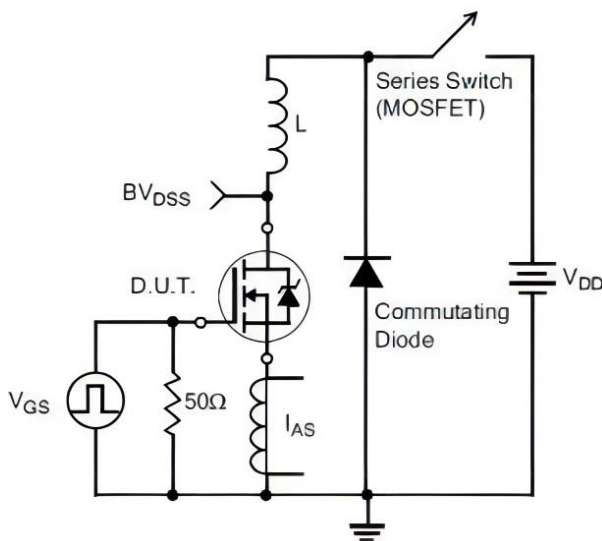

Unclamped Inductive Switching Test Circuit

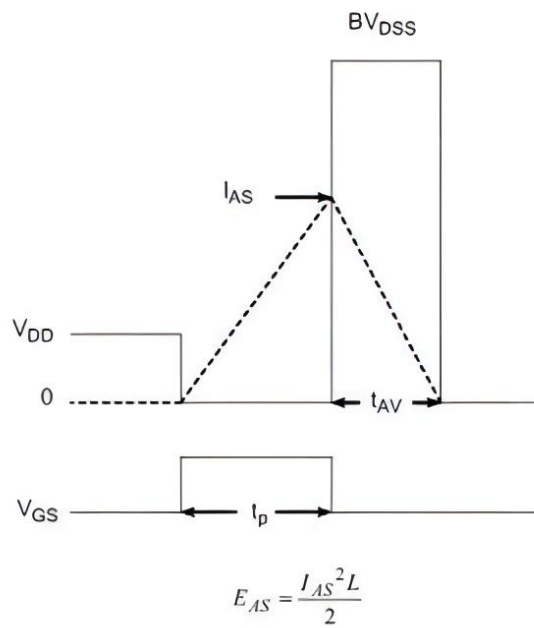

Unclamped Inductive Switching Waveforms

PDFN5*6 Package

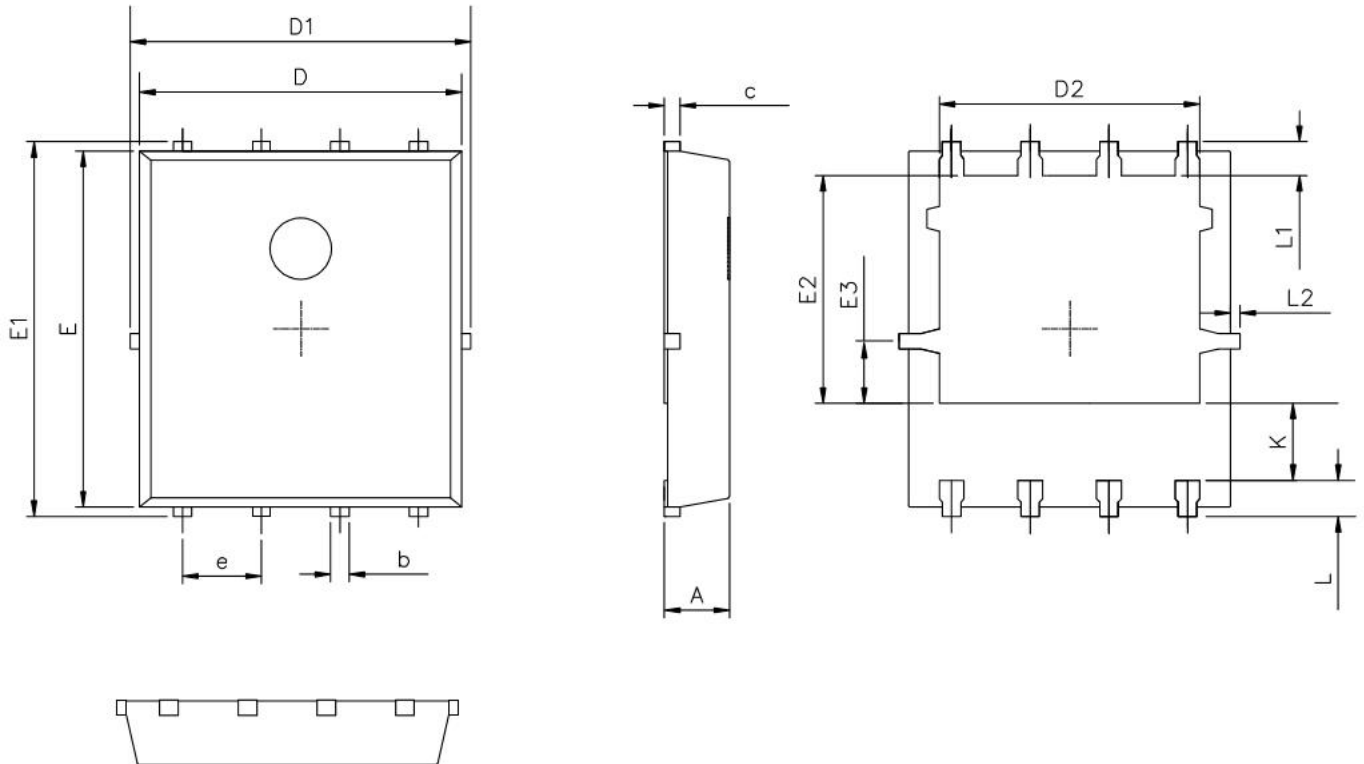

RECOMMENDED LAND PATTERN

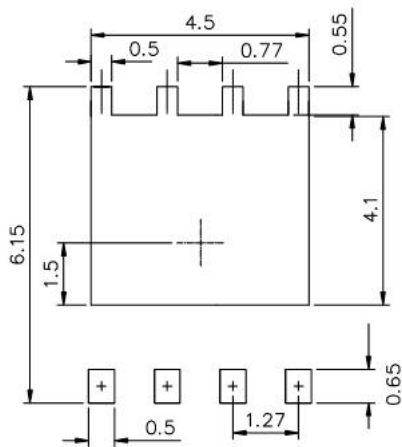

Symbol	Dimensions In Millimeters		
	min.	nom.	max.
A	0.9	1	1.1
b	0.25	0.35	0.5
c	0.1	0.2	0.3
D	0.48	5	5.3
D1	0.49	5.1	5.5
D2	3.92	4.02	4.2
E	5.65	5.75	5.85
E1	5.9	6.05	6.2
E2	3.32	3.52	3.78
E3	0.8	0.9	1
e		1.27	
L	0.4	0.55	0.7
L1		0.65	
L2	0		0.15
K	1	1.3	1.5

Disclaimers:

Bridgelux WuXi has made reasonable commercial efforts to ensure that the information given in this data sheet is correct. However, it must clearly be understood that such information is for guidance only and does not constitute any representation or form part of any offer or contract.

For documents and material available from this data sheet, Bridgelux WuXi does not warrant or assume any legal liability or responsibility for the accuracy, completeness, or usefulness of any information, product, technology or process disclosed hereunder.

Bridgelux WuXi reserves the rights to at its own discretion to make any changes or improvements to this data sheet. Unless said data sheet is incorporated into the formal contract, any customer should not rely on the information as any specification or product parameters duly committed by Bridgelux WuXi. Customers are hereby advised to verify that the information contained herein is current and complete before the entering of any contract or acknowledgement of any purchase order. Accordingly, all products specified hereunder shall be sold subject to Bridgelux WuXi's terms and conditions supplied at the time of order acknowledgement. Except where agreed upon by contractual agreement, testing of all parameters of each product is not necessarily performed.

Bridgelux WuXi does not warrant or convey any license either expressed or implied under its patent rights, nor the rights of others. Reproduction of information contained herein shall be only permissible if such reproduction is without any modification or alteration. Reproduction of this information with any alteration is an unfair and deceptive business practice. Bridgelux WuXi is not responsible or liable for such altered documentation.

Resale of Bridgelux WuXi's products with statements different from or beyond the parameters stated by Bridgelux WuXi for that product or service voids all express or implied warranties for the associated Bridgelux WuXi's product or service and is unfair and deceptive business practice. Bridgelux WuXi is not responsible or liable for any such statements.

Bridgelux WuXi's products are not authorized for use as critical components in life support devices or systems without the express written approval of Bridgelux WuXi. As used herein:

1. Life support devices or systems are devices or systems which, (a) are intended for surgical implant into the body, or (b) support or sustain life, and whose failure to perform, when properly used in accordance with instructions for use provided in the labeling, can be reasonably expected to result in a significant injury to the user.
2. A critical component is any component of a life support device or system whose failure to perform can be reasonably expected to cause the failure of the life support device or system, or to affect its safety or effectiveness.