



Bridgelux[®] Gen. 7 Décor Series[™] Class A LED Array

Product Data Sheet DS95



BXRC-30A1001	30A2001	30A4001	30A10K1
BXRC-35A1001	35A2001	35A4001	35A10K1
BXRC-40A1001	40A2001	40A4001	40A10K1

Introduction

Décor Series™

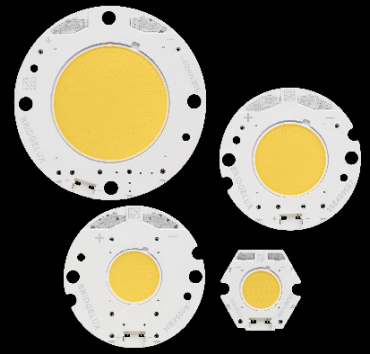

Bridgelux Décor Series is our state of the art color line designed specifically for premium applications, producing unmatched LED light quality with brilliant color-rendering options. Light and color are powerful mediums that influence experience and well-being, and Décor Series LEDs offer pleasing lighting palettes that are inspiring. Bridgelux Décor Series color points are available on Vero® SE Series, Vero® Series, and H Series™.

Bridgelux® Décor Series™ Class A products are a revolutionary advancement in lighting designed to match how humans perceive and prefer light. The Class A specification was created by the Lighting Research Center (LRC) behavior studies in conjunction with Bridgelux and other Alliance for Solid-State Illumination Systems and Technologies (ASSIST) members. Based on human factor response testing, the Décor Series Class A products provide vibrant, natural and brilliant light, evoking an emotional attraction and response. The Décor Series Class A products were developed for high-end retail, museum, architectural, building and hospitality applications.

Bridgelux Décor Series Class A products are available on all Vero® Series form factors. The Vero platform has been engineered with advanced connectivity options and can operate over a range of currents, enabling multiple degrees of flexibility in luminaire design optimization.

Features

- Light quality is based on human perception of color and light
- High gamut area index (GAI)
- No harmful UV or near IR light in the spectrum
- Substantially broader gamut area and color spectrum than halogen
- Radial die pattern enhances optical uniformity
- Based on Bridgelux Vero Series COB LED array platform

Benefits

- Broad application coverage for interior and exterior lighting
- Flexibility for application driven lighting design requirements
- High quality, true color reproduction
- Uniform, consistent white light
- Flexibility in design optimization
- Enhanced ease of use and manufacturability

Contents

Product Feature Map	2
Product Nomenclature	2
Product Selection Guide	3
Performance at Commonly Used Drive Currents	6
Electrical Characteristics	11
Eye Safety	12
Absolute Maximum Ratings	13
Performance Curves	14
Typical Radiation Pattern	20
Mechanical Dimensions	21
Packaging and Labeling	25
Design Resources	28
Precautions	28
Disclaimers	28
About Bridgelux	29

Product Selection Guide

The following product configurations are available:

Table 1: Selection Guide, Pulsed Measurement Data ($T_j = T_c = 25^\circ\text{C}$)

Product	Part Number	Nominal CCT ¹ (K)	GAI ²	CRI ³	Nominal Drive Current ⁴ (mA)	Typical Pulsed Flux ^{5,6,7} $T_c = 25^\circ\text{C}$ (lm)	Minimum Pulsed Flux ^{7,8} $T_c = 25^\circ\text{C}$ (lm)	Typical V_f (V)	Typical Power (W)	Typical Efficacy (lm/W)
Décor Class A Vero 10	BXRC-30A1001-B-73	3000	80	93	270	1086	956	35.0	9.4	116
Décor Class A Vero 10	BXRC-30A1001-C-73	3000	80	93	360	1448	1274	35.0	12.5	116
Décor Class A Vero 10	BXRC-30A1001-D-73	3000	80	93	350	1056	929	26.0	9.1	116
Décor Class A Vero 10	BXRC-35A1001-B-73	3500	80	93	270	1170	1030	35.0	9.4	125
Décor Class A Vero 10	BXRC-35A1001-C-73	3500	80	93	360	1560	1373	35.0	12.5	125
Décor Class A Vero 10	BXRC-35A1001-D-73	3500	80	93	350	1138	1001	26.0	9.1	125
Décor Class A Vero 10	BXRC-40A1001-B-73	4000	80	93	270	1245	1096	35.0	9.4	133
Décor Class A Vero 10	BXRC-40A1001-C-73	4000	80	93	360	1660	1461	35.0	12.5	133
Décor Class A Vero 10	BXRC-40A1001-D-73	4000	80	93	350	1210	1065	26.0	9.1	133
Décor Class A Vero 13	BXRC-30A2001-B-73	3000	80	93	450	1873	1686	35.0	15.6	120
Décor Class A Vero 13	BXRC-30A2001-C-73	3000	80	93	630	2622	2360	35.0	21.9	120
Décor Class A Vero 13	BXRC-30A2001-D-73	3000	80	93	500	1907	1717	31.8	15.9	120
Décor Class A Vero 13	BXRC-35A2001-B-73	3500	80	93	450	2014	1812	35.0	15.6	129
Décor Class A Vero 13	BXRC-35A2001-C-73	3500	80	93	630	2819	2537	35.0	21.9	129
Décor Class A Vero 13	BXRC-35A2001-D-73	3500	80	93	500	2050	1845	31.8	15.9	129
Décor Class A Vero 13	BXRC-40A2001-B-73	4000	80	93	450	2154	1939	35.0	15.6	138
Décor Class A Vero 13	BXRC-40A2001-C-73	4000	80	93	630	3015	2714	35.0	21.9	138
Décor Class A Vero 13	BXRC-40A2001-D-73	4000	80	93	500	2194	1975	31.8	15.9	138
Décor Class A Vero 18	BXRC-30A4001-B-73	3000	80	93	900	3745	3371	35.0	31.2	120
Décor Class A Vero 18	BXRC-30A4001-C-73	3000	80	93	1170	4870	4383	35.0	40.6	120
Décor Class A Vero 18	BXRC-30A4001-D-73	3000	80	93	1050	3641	3277	29.0	30.4	120
Décor Class A Vero 18	BXRC-35A4001-B-73	3500	80	93	900	4026	3623	35.0	31.2	129
Décor Class A Vero 18	BXRC-35A4001-C-73	3500	80	93	1170	5235	4711	35.0	40.6	129
Décor Class A Vero 18	BXRC-35A4001-D-73	3500	80	93	1050	3915	3523	29.0	30.4	129
Décor Class A Vero 18	BXRC-40A4001-B-73	4000	80	93	900	4307	3876	35.0	31.2	138
Décor Class A Vero 18	BXRC-40A4001-C-73	4000	80	93	1170	5600	5040	35.0	40.6	138
Décor Class A Vero 18	BXRC-40A4001-D-73	4000	80	93	1050	4188	3769	29.0	30.4	138
Décor Class A Vero 29	BXRC-30A10K1-B-73	3000	80	93	1800	11237	10113	52.0	93.6	120
Décor Class A Vero 29	BXRC-30A10K1-C-73	3000	80	93	1710	14233	12810	69.4	118.6	120
Décor Class A Vero 29	BXRC-30A10K1-D-73	3000	80	93	2100	9468	8521	37.6	78.9	120
Décor Class A Vero 29	BXRC-35A10K1-B-73	3500	80	93	1800	12080	10872	52.0	93.6	129
Décor Class A Vero 29	BXRC-35A10K1-C-73	3500	80	93	1710	15301	13771	69.4	118.6	129
Décor Class A Vero 29	BXRC-35A10K1-D-73	3500	80	93	2100	10178	9160	37.6	78.9	129
Décor Class A Vero 29	BXRC-40A10K1-B-73	4000	80	93	1800	12922	11630	52.0	93.6	138
Décor Class A Vero 29	BXRC-40A10K1-C-73	4000	80	93	1710	16368	14731	69.4	118.6	138
Décor Class A Vero 29	BXRC-40A10K1-D-73	4000	80	93	2100	10888	9799	37.6	78.9	138

Notes for Table 1:

1. Nominal CCT is defined by the Lighting Research Center's Class A definition. The center of the Class A color bin is on the corresponding isothermal line.
2. To help ensure optimal fixture level performance, GAI is measured at the fixture level, on axis, at a case temperature of 70°C. GAI may vary depending on fixture design and performance.
3. CRI Values are specified as typical.
4. Drive current is referred to as nominal drive current.
5. Products tested under pulsed condition (10ms pulse width) at nominal test current where T_j (junction temperature) - T_c (case temperature) = 25°C.
6. Typical performance values are provided as a reference only and are not a guarantee of performance.
7. Bridgelux maintains a $\pm 7\%$ tolerance on flux measurements.
8. Minimum flux values at the nominal test current are guaranteed by 100% test.

Product Selection Guide

The following product configurations are available:

Table 2: Selection Guide, Stabilized DC Performance ($T_c = 70^\circ\text{C}$) ^{7,8}

Product	Part Number	Nominal CCT ¹ (K)	GAI ²	CRI ³	Nominal Drive Current ⁴ (mA)	Typical DC Flux ^{5,6} $T_c = 70^\circ\text{C}$ (lm)	Minimum DC Flux ^{6,9} $T_c = 70^\circ\text{C}$ (lm)	Typical V_f (V)	Typical Power (W)	Typical Efficacy (lm/W)
Décor Class A Vero 10	BXRC-30A1001-B-73	3000	80	93	270	1010	889	34.3	9.3	109
Décor Class A Vero 10	BXRC-30A1001-C-73	3000	80	93	360	1347	1185	34.3	12.3	109
Décor Class A Vero 10	BXRC-30A1001-D-73	3000	80	93	350	982	864	25.5	8.9	110
Décor Class A Vero 10	BXRC-35A1001-B-73	3500	80	93	270	1088	958	34.3	9.3	118
Décor Class A Vero 10	BXRC-35A1001-C-73	3500	80	93	360	1451	1277	34.3	12.3	118
Décor Class A Vero 10	BXRC-35A1001-D-73	3500	80	93	350	1058	931	25.5	8.9	119
Décor Class A Vero 10	BXRC-40A1001-B-73	4000	80	93	270	1158	1019	34.3	9.3	125
Décor Class A Vero 10	BXRC-40A1001-C-73	4000	80	93	360	1544	1359	34.3	12.3	125
Décor Class A Vero 10	BXRC-40A1001-D-73	4000	80	93	350	1125	990	25.5	8.9	126
Décor Class A Vero 13	BXRC-30A2001-B-73	3000	80	93	450	1742	1568	34.4	15.5	113
Décor Class A Vero 13	BXRC-30A2001-C-73	3000	80	93	630	2438	2195	34.4	21.6	113
Décor Class A Vero 13	BXRC-30A2001-D-73	3000	80	93	500	1774	1597	31.2	15.6	114
Décor Class A Vero 13	BXRC-35A2001-B-73	3500	80	93	450	1873	1685	34.4	15.5	121
Décor Class A Vero 13	BXRC-35A2001-C-73	3500	80	93	630	2622	2359	34.4	21.6	121
Décor Class A Vero 13	BXRC-35A2001-D-73	3500	80	93	500	1907	1716	31.2	15.6	122
Décor Class A Vero 13	BXRC-40A2001-B-73	4000	80	93	450	2003	1803	34.4	15.5	130
Décor Class A Vero 13	BXRC-40A2001-C-73	4000	80	93	630	2804	2524	34.4	21.6	130
Décor Class A Vero 13	BXRC-40A2001-D-73	4000	80	93	500	2040	1837	31.2	15.6	131
Décor Class A Vero 18	BXRC-30A4001-B-73	3000	80	93	900	3483	3135	34.3	30.9	113
Décor Class A Vero 18	BXRC-30A4001-C-73	3000	80	93	1170	4529	4076	34.3	40.2	113
Décor Class A Vero 18	BXRC-30A4001-D-73	3000	80	93	1050	3386	3048	28.5	29.9	113
Décor Class A Vero 18	BXRC-35A4001-B-73	3500	80	93	900	3744	3369	34.3	30.9	121
Décor Class A Vero 18	BXRC-35A4001-C-73	3500	80	93	1170	4869	4381	34.3	40.2	121
Décor Class A Vero 18	BXRC-35A4001-D-73	3500	80	93	1050	3641	3276	28.5	29.9	122
Décor Class A Vero 18	BXRC-40A4001-B-73	4000	80	93	900	4006	3605	34.3	30.9	130
Décor Class A Vero 18	BXRC-40A4001-C-73	4000	80	93	1170	5208	4687	34.3	40.2	130
Décor Class A Vero 18	BXRC-40A4001-D-73	4000	80	93	1050	3895	3505	28.5	29.9	130
Décor Class A Vero 29	BXRC-30A10K1-B-73	3000	80	93	1800	10450	9405	50.9	91.6	114
Décor Class A Vero 29	BXRC-30A10K1-C-73	3000	80	93	1710	13237	11913	67.9	116.1	114
Décor Class A Vero 29	BXRC-30A10K1-D-73	3000	80	93	2100	8805	7925	36.8	77.3	114
Décor Class A Vero 29	BXRC-35A10K1-B-73	3500	80	93	1800	11234	10111	50.9	91.6	123
Décor Class A Vero 29	BXRC-35A10K1-C-73	3500	80	93	1710	14230	12807	67.9	116.1	123
Décor Class A Vero 29	BXRC-35A10K1-D-73	3500	80	93	2100	9466	8519	36.8	77.3	122
Décor Class A Vero 29	BXRC-40A10K1-B-73	4000	80	93	1800	12017	10816	50.9	91.6	131
Décor Class A Vero 29	BXRC-40A10K1-C-73	4000	80	93	1710	15222	13700	67.9	116.1	131
Décor Class A Vero 29	BXRC-40A10K1-D-73	4000	80	93	2100	10126	9113	36.8	77.3	131

Notes for Table 2:

- Nominal CCT is defined by the Lighting Research Center's Class A definition. The center of the Class A color bin is on the corresponding isothermal line.
- To help ensure optimal fixture level performance, GAI is measured at the fixture level, on axis, at a case temperature of 70°C. GAI may vary depending on fixture design and performance.
- CRI Values are specified as typical.
- Drive current is referred to as nominal drive current.
- Typical performance values are provided as a reference only and are not a guarantee of performance.
- Bridgelux maintains a ±7% tolerance on flux measurements.
- Typical stabilized DC performance values are provided as reference only and are not a guarantee of performance.
- Typical performance is estimated based on operation under DC (direct current) with LED array mounted onto a heat sink with thermal interface material and the case temperature maintained at specified temperature. Based on Bridgelux test setup, values may vary depending on the thermal design of the luminaire and/or the exposed environment to which the product is subjected.
- Minimum flux values at elevated temperatures are provided for reference only and are not guaranteed by 100% production testing. Based on Bridgelux test setup, values may vary depending on the thermal design of the luminaire and/or the exposed environment to which the product is subjected.

Product Selection Guide

The following product configurations are available:

Table 3: Selection Guide, Stabilized DC Performance ($T_c = 85^\circ\text{C}$) ^{7,8}

Product	Part Number	Nominal CCT ¹ (K)	GAI ²	CRI ³	Nominal Drive Current ⁴ (mA)	Typical DC Flux ^{5,6} $T_c = 85^\circ\text{C}$ (lm)	Minimum DC Flux ^{6,9} $T_c = 85^\circ\text{C}$ (lm)	Typical V_f (V)	Typical Power (W)	Typical Efficacy (lm/W)
Décor Class A Vero 10	BXRC-30A1001-B-73	3000	80	93	270	977	860	34.0	9.2	106
Décor Class A Vero 10	BXRC-30A1001-C-73	3000	80	93	360	1303	1147	34.0	12.3	106
Décor Class A Vero 10	BXRC-30A1001-D-73	3000	80	93	350	950	836	25.3	8.9	107
Décor Class A Vero 10	BXRC-35A1001-B-73	3500	80	93	270	1053	927	34.0	9.2	115
Décor Class A Vero 10	BXRC-35A1001-C-73	3500	80	93	360	1404	1236	34.0	12.3	115
Décor Class A Vero 10	BXRC-35A1001-D-73	3500	80	93	350	1024	901	25.3	8.9	116
Décor Class A Vero 10	BXRC-40A1001-B-73	4000	80	93	270	1121	986	34.0	9.2	122
Décor Class A Vero 10	BXRC-40A1001-C-73	4000	80	93	360	1494	1315	34.0	12.3	122
Décor Class A Vero 10	BXRC-40A1001-D-73	4000	80	93	350	1089	959	25.3	8.9	123
Décor Class A Vero 13	BXRC-30A2001-B-73	3000	80	93	450	1686	1517	34.1	15.4	110
Décor Class A Vero 13	BXRC-30A2001-C-73	3000	80	93	630	2360	2124	34.1	21.5	110
Décor Class A Vero 13	BXRC-30A2001-D-73	3000	80	93	500	1716	1545	31.0	15.5	111
Décor Class A Vero 13	BXRC-35A2001-B-73	3500	80	93	450	1813	1631	34.1	15.4	118
Décor Class A Vero 13	BXRC-35A2001-C-73	3500	80	93	630	2537	2283	34.1	21.5	118
Décor Class A Vero 13	BXRC-35A2001-D-73	3500	80	93	500	1845	1661	31.0	15.5	119
Décor Class A Vero 13	BXRC-40A2001-B-73	4000	80	93	450	1939	1745	34.1	15.4	126
Décor Class A Vero 13	BXRC-40A2001-C-73	4000	80	93	630	2714	2443	34.1	21.5	126
Décor Class A Vero 13	BXRC-40A2001-D-73	4000	80	93	500	1975	1778	31.0	15.5	127
Décor Class A Vero 18	BXRC-30A4001-B-73	3000	80	93	900	3371	3034	34.1	30.7	110
Décor Class A Vero 18	BXRC-30A4001-C-73	3000	80	93	1170	4383	3945	34.1	39.9	110
Décor Class A Vero 18	BXRC-30A4001-D-73	3000	80	93	1050	3277	2949	28.3	29.7	110
Décor Class A Vero 18	BXRC-35A4001-B-73	3500	80	93	900	3623	3261	34.1	30.7	118
Décor Class A Vero 18	BXRC-35A4001-C-73	3500	80	93	1170	4712	4240	34.1	39.9	118
Décor Class A Vero 18	BXRC-35A4001-D-73	3500	80	93	1050	3524	3171	28.3	29.7	119
Décor Class A Vero 18	BXRC-40A4001-B-73	4000	80	93	900	3876	3488	34.1	30.7	126
Décor Class A Vero 18	BXRC-40A4001-C-73	4000	80	93	1170	5040	4536	34.1	39.9	126
Décor Class A Vero 18	BXRC-40A4001-D-73	4000	80	93	1050	3769	3392	28.3	29.7	127
Décor Class A Vero 29	BXRC-30A10K1-B-73	3000	80	93	1800	10113	9102	50.5	90.9	111
Décor Class A Vero 29	BXRC-30A10K1-C-73	3000	80	93	1710	12810	11529	67.4	115.3	111
Décor Class A Vero 29	BXRC-30A10K1-D-73	3000	80	93	2100	8521	7669	36.6	76.8	111
Décor Class A Vero 29	BXRC-35A10K1-B-73	3500	80	93	1800	10872	9785	50.5	90.9	120
Décor Class A Vero 29	BXRC-35A10K1-C-73	3500	80	93	1710	13771	12394	67.4	115.2	120
Décor Class A Vero 29	BXRC-35A10K1-D-73	3500	80	93	2100	9160	8244	36.6	76.8	119
Décor Class A Vero 29	BXRC-40A10K1-B-73	4000	80	93	1800	11630	10467	50.5	90.9	128
Décor Class A Vero 29	BXRC-40A10K1-C-73	4000	80	93	1710	14731	13258	67.4	115.2	128
Décor Class A Vero 29	BXRC-40A10K1-D-73	4000	80	93	2100	9799	8819	36.6	76.8	128

Notes for Table 3:

- Nominal CCT is defined by the Lighting Research Center's Class A definition. The center of the Class A color bin is on the corresponding isothermal line.
- To help ensure optimal fixture level performance, GAI is measured at the fixture level, on axis, at a case temperature of 70°C . GAI may vary depending on fixture design and performance.
- CRI Values are specified as typical.
- Drive current is referred to as nominal drive current.
- Typical performance values are provided as a reference only and are not a guarantee of performance.
- Bridgelux maintains a $\pm 7\%$ tolerance on flux measurements.
- Typical stabilized DC performance values are provided as reference only and are not a guarantee of performance.
- Typical performance is estimated based on operation under DC (direct current) with LED array mounted onto a heat sink with thermal interface material and the case temperature maintained at specified temperature. Based on Bridgelux test setup, values may vary depending on the thermal design of the luminaire and/or the exposed environment to which the product is subjected.
- Minimum flux values at elevated temperatures are provided for reference only and are not guaranteed by 100% production testing. Based on Bridgelux test setup, values may vary depending on the thermal design of the luminaire and/or the exposed environment to which the product is subjected.

Performance at Commonly Used Drive Currents

Vero LED arrays are tested to the specifications shown using the nominal drive currents in Table 1. Vero may also be driven at other drive currents dependent on specific application design requirements. The performance at any drive current can be derived from the current vs. voltage characteristics shown in Figure 1-12 and the flux vs. current characteristics shown in Figures 13-24. The performance at commonly used drive currents is summarized in Table 4.

Table 4: Product Performance at Commonly Used Drive Currents

Product	Part Number	GAI	CRI	Drive Current ¹ (mA)	Typical V _f T _c = 25°C (V)	Typical Power T _c = 25°C (W)	Typical Flux ² T _c = 25°C (lm)	Typical DC Flux ³ T _c = 85°C (lm)	Typical Efficacy T _c = 25°C (lm/W)
Décor Class A Vero 10	BXRC-30A1001-B-73	80	93	135	33.3	4.5	579	521	129
				180	33.8	6.1	759	683	125
				270	35.0	9.5	1086	977	116
				405	36.4	14.8	1593	1434	108
				540	37.8	20.4	2041	1837	100
Décor Class A Vero 10	BXRC-30A1001-C-73	80	93	180	33.3	6.0	770	693	129
				240	33.8	8.1	1009	908	124
				360	35.0	12.6	1448	1303	116
				540	36.4	19.7	2108	1898	107
				720	37.7	27.1	2693	2424	99
Décor Class A Vero 10	BXRC-30A1001-D-73	80	93	175	24.9	4.4	564	507	129
				233	25.4	5.9	740	666	125
				350	26.0	9.1	1056	950	116
				525	27.4	14.4	1554	1399	108
				700	28.4	19.9	1991	1792	100
Décor Class A Vero 10	BXRC-35A1001-B-73	80	93	135	33.3	4.5	623	561	139
				180	33.8	6.1	817	736	134
				270	35.0	9.5	1170	1053	125
				405	36.4	14.8	1716	1545	116
				540	37.8	20.4	2199	1979	108
Décor Class A Vero 10	BXRC-35A1001-C-73	80	93	180	33.3	6.0	829	746	139
				240	33.8	8.1	1087	978	134
				360	35.0	12.6	1560	1404	125
				540	36.4	19.7	2272	2044	116
				720	37.7	27.1	2902	2612	107
Décor Class A Vero 10	BXRC-35A1001-D-73	80	93	175	24.9	4.4	608	547	139
				233	25.4	5.9	797	717	135
				350	26.0	9.1	1138	1024	125
				525	27.4	14.4	1675	1508	117
				700	28.4	19.9	2146	1931	108

Notes for Table 4:

1. Alternate drive currents in Table 4 are provided for reference only and are not a guarantee of performance.
2. Bridgelux maintains a ± 7% tolerance on flux measurements.
3. Typical stabilized DC performance values are provided as reference only and are not a guarantee of performance.

Performance at Commonly Used Drive Currents

Table 4: Product Performance at Commonly Used Drive Currents (Continued)

Product	Part Number	GAI	CRI	Drive Current ¹ (mA)	Typical V _f T _c = 25°C (V)	Typical Power T _c = 25°C (W)	Typical Flux ² T _c = 25°C (lm)	Typical DC Flux ³ T _c = 85°C (lm)	Typical Efficacy T _c = 25°C (lm/W)
Décor Class A Vero 10	BXRC-40A1001-B-73	80	93	135	33.3	4.5	663	581	148
				180	33.8	6.1	870	763	143
				270	35.0	9.5	1245	1089	133
				405	36.4	14.8	1827	1603	124
Décor Class A Vero 10	BXRC-40A1001-C-73	80	93	540	37.8	20.4	2340	2054	115
				180	33.3	6.0	883	459	147
				240	33.8	8.1	1156	889	142
				360	35.0	12.6	1660	1686	133
Décor Class A Vero 10	BXRC-40A1001-D-73	80	93	540	36.4	19.7	2417	2436	123
				720	37.7	27.1	3088	3107	114
				175	24.9	4.4	646	638	148
				233	25.4	5.9	848	1234	143
Décor Class A Vero 10	BXRC-40A1001-D-73	80	93	350	26.0	9.1	1210	2360	133
				525	27.4	14.4	1781	3387	124
				700	28.4	19.9	2282	4323	115
				113	32.3	3.7	510	454	140
Décor Class A Vero 13	BXRC-30A2001-B-73	80	93	225	33.2	7.5	987	881	132
				450	35.0	15.8	1873	1716	120
				675	36.3	24.5	2707	2425	111
				900	37.5	33.7	3453	3101	102
Décor Class A Vero 13	BXRC-30A2001-C-73	80	93	158	32.3	5.1	708	494	139
				315	33.2	10.5	1371	956	131
				630	35.0	22.1	2622	1813	120
				945	36.4	34.4	3763	2619	109
Décor Class A Vero 13	BXRC-30A2001-C-73	80	93	1260	37.8	47.6	4803	3341	101
				125	29.6	3.7	505	685	137
				250	30.3	7.6	979	1327	129
				500	31.8	15.9	1907	2537	120
Décor Class A Vero 13	BXRC-30A2001-D-73	80	93	750	33.2	24.9	2695	3641	108
				1000	34.4	34.4	3446	4648	100
				113	32.3	3.7	548	488	150
				225	33.2	7.5	1062	947	142
Décor Class A Vero 13	BXRC-35A2001-B-73	80	93	450	35.0	15.8	2014	1845	129
				675	36.3	24.5	2911	2607	119
				900	37.5	33.7	3713	3334	110
				158	32.3	5.1	762	670	149
Décor Class A Vero 13	BXRC-35A2001-C-73	80	93	315	33.2	10.5	1474	1298	141
				630	35.0	22.1	2819	2481	129
				945	36.4	34.4	4046	3561	118
				1260	37.8	47.6	5164	4544	109
Décor Class A Vero 13	BXRC-35A2001-D-73	80	93	125	29.6	3.7	543	478	147
				250	30.3	7.6	1052	926	139
				500	31.8	15.9	2050	1804	129
				750	33.2	24.9	2897	2549	116
Décor Class A Vero 13	BXRC-35A2001-D-73	80	93	1000	34.4	34.4	3704	3260	108

Notes for Table 4:

1. Alternate drive currents in Table 4 are provided for reference only and are not a guarantee of performance.
2. Bridgelux maintains a ± 7% tolerance on flux measurements.
3. Typical stabilized DC performance values are provided as reference only and are not a guarantee of performance.

Performance at Commonly Used Drive Currents

Table 4: Product Performance at Commonly Used Drive Currents (Continued)

Product	Part Number	GAI	CRI	Drive Current ¹ (mA)	Typical V_f $T_c = 25^\circ\text{C}$ (V)	Typical Power $T_c = 25^\circ\text{C}$ (W)	Typical Flux ² $T_c = 25^\circ\text{C}$ (lm)	Typical DC Flux ³ $T_c = 85^\circ\text{C}$ (lm)	Typical Efficacy $T_c = 25^\circ\text{C}$ (lm/W)
Décor Class A Vero 13	BXRC-40A2001-B-73	80	93	113	32.3	3.7	587	528	161
				225	33.2	7.5	1135	1022	152
				450	35.0	15.8	2154	1939	138
				675	36.3	24.5	3113	2802	127
				900	37.5	33.7	3971	3574	118
Décor Class A Vero 13	BXRC-40A2001-C-73	80	93	158	32.3	5.1	815	733	159
				315	33.2	10.5	1577	1419	151
				630	35.0	22.1	3015	2714	138
				945	36.4	34.4	4327	3895	126
				1260	37.8	47.6	5523	4971	116
Décor Class A Vero 13	BXRC-40A2001-D-73	80	93	125	29.6	3.7	581	523	157
				250	30.3	7.6	1126	1013	148
				500	31.8	15.9	2194	1975	138
				750	33.2	24.9	3100	2790	125
				1000	34.4	34.4	3964	3568	115
Décor Class A Vero 18	BXRC-30A4001-B-73	80	93	450	33.3	15.0	2011	1810	134
				600	33.9	20.4	2638	2374	129
				900	35.0	31.5	3745	3371	120
				1350	36.7	49.5	5570	5013	113
				1800	38.0	68.4	7168	6451	105
Décor Class A Vero 18	BXRC-30A4001-C-73	80	93	585	33.4	19.5	2545	2290	130
				780	34.0	26.5	3334	3001	126
				1170	35.0	41.0	4870	4383	120
				1755	36.8	64.5	7006	6305	109
				2340	38.1	89.3	8987	8088	101
Décor Class A Vero 18	BXRC-30A4001-D-73	80	93	525	27.7	14.6	1940	1746	133
				700	28.2	19.8	2522	2270	128
				1050	29.0	30.5	3641	3277	120
				1575	30.4	47.9	5201	4681	109
				2100	31.5	66.2	6620	5958	100
Décor Class A Vero 18	BXRC-35A4001-B-73	80	93	450	33.3	15.0	2162	1945	144
				600	33.9	20.4	2836	2552	139
				900	35.0	31.5	4026	3623	129
				1350	36.7	49.5	5988	5389	121
				1800	38.0	68.4	7705	6935	113
Décor Class A Vero 18	BXRC-35A4001-C-73	80	93	585	33.4	19.5	2735	2462	140
				780	34.0	26.5	3584	3226	135
				1170	35.0	41.0	5235	4712	129
				1755	36.8	64.5	7531	6778	117
				2340	38.1	89.3	9660	8694	108
Décor Class A Vero 18	BXRC-35A4001-D-73	80	93	525	27.7	14.6	2086	1877	143
				700	28.2	19.8	2712	2441	137
				1050	29.0	30.5	3915	3524	129
				1575	30.4	47.9	5592	5033	117
				2100	31.5	66.2	7119	6407	108

Notes for Table 4:

1. Alternate drive currents in Table 4 are provided for reference only and are not a guarantee of performance.
2. Bridgelux maintains a $\pm 7\%$ tolerance on flux measurements.
3. Typical stabilized DC performance values are provided as reference only and are not a guarantee of performance.

Performance at Commonly Used Drive Currents

Table 4: Product Performance at Commonly Used Drive Currents (Continued)

Product	Part Number	GAI	CRI	Drive Current ¹ (mA)	Typical V_f $T_c = 25^\circ\text{C}$ (V)	Typical Power $T_c = 25^\circ\text{C}$ (W)	Typical Flux ² $T_c = 25^\circ\text{C}$ (lm)	Typical DC Flux ³ $T_c = 85^\circ\text{C}$ (lm)	Typical Efficacy $T_c = 25^\circ\text{C}$ (lm/W)
Décor Class A Vero 18	BXRC-40A4001-B-73	80	93	450	33.3	15.0	2312	2081	154
				600	33.9	20.4	3033	2730	149
				900	35.0	31.5	4307	3876	138
				1350	36.7	49.5	6406	5765	129
				1800	38.0	68.4	8243	7419	120
Décor Class A Vero 18	BXRC-40A4001-C-73	80	93	585	33.4	19.5	2926	2633	150
				780	34.0	26.5	3834	3451	145
				1170	35.0	41.0	5600	5040	138
				1755	36.8	64.5	8056	7251	125
				2340	38.1	89.3	10334	9300	116
Décor Class A Vero 18	BXRC-40A4001-D-73	80	93	525	27.7	14.6	2231	2008	153
				700	28.2	19.8	2901	2611	147
				1050	29.0	30.5	4188	3769	138
				1575	30.4	47.9	5982	5384	125
				2100	31.5	66.2	7615	6854	115
Décor Class A Vero 29	BXRC-30A10K1-B-73	80	93	900	49.6	44.7	5888	5299	132
				1200	50.5	60.6	7769	6992	128
				1800	52.0	93.6	11237	10113	120
				2700	54.1	146.1	16568	14911	113
				3600	55.8	201.0	21362	19225	106
Décor Class A Vero 29	BXRC-30A10K1-C-73	80	93	855	66.2	56.6	8085	7277	143
				1140	67.3	76.7	10276	9249	134
				1710	69.4	118.7	14233	12810	120
				2565	72.1	185.0	20191	18172	109
				3420	74.4	254.6	25308	22777	99
Décor Class A Vero 29	BXRC-30A10K1-D-73	80	93	1050	35.4	37.2	5208	4687	140
				1400	36.2	50.6	6702	6032	132
				2100	37.6	79.0	9468	8521	120
				3150	39.5	124.4	13479	12131	108
				4200	41.2	172.9	16988	15290	98
Décor Class A Vero 29	BXRC-35A10K1-B-73	80	93	900	49.6	44.7	6330	5697	142
				1200	50.5	60.6	8352	7517	138
				1800	52.0	93.6	12080	10872	129
				2700	54.1	146.1	17811	16030	122
				3600	55.8	201.0	22964	20668	114
Décor Class A Vero 29	BXRC-35A10K1-C-73	80	93	855	66.2	56.6	8692	7823	154
				1140	67.3	76.7	11048	9943	144
				1710	69.4	118.7	15301	13771	129
				2565	72.1	185.0	21706	19536	117
				3420	74.4	254.6	27207	24486	107
Décor Class A Vero 29	BXRC-35A10K1-D-73	80	93	1050	35.4	37.2	5598	5039	150
				1400	36.2	50.6	7205	6485	142
				2100	37.6	79.0	10178	9160	129
				3150	39.5	124.4	14490	13041	117
				4200	41.2	172.9	18262	16436	106

Notes for Table 4:

1. Alternate drive currents in Table 4 are provided for reference only and are not a guarantee of performance.
2. Bridgelux maintains a $\pm 7\%$ tolerance on flux measurements.
3. Typical stabilized DC performance values are provided as reference only and are not a guarantee of performance.

Performance at Commonly Used Drive Currents

Table 4: Product Performance at Commonly Used Drive Currents (Continued)

Product	Part Number	GAI	CRI	Drive Current ¹ (mA)	Typical V_f $T_c = 25^\circ\text{C}$ (V)	Typical Power $T_c = 25^\circ\text{C}$ (W)	Typical Flux ² $T_c = 25^\circ\text{C}$ (lm)	Typical DC Flux ³ $T_c = 85^\circ\text{C}$ (lm)	Typical Efficacy $T_c = 25^\circ\text{C}$ (lm/W)
Décor Class A Vero 29	BXRC-40A10K1-B-73	80	93	900	49.6	44.7	6771	6094	152
				1200	50.5	60.6	8934	8041	148
				1800	52.0	93.6	12922	11630	138
				2700	54.1	146.1	19052	17147	130
				3600	55.8	201.0	24565	22108	122
Décor Class A Vero 29	BXRC-40A10K1-C-73	80	93	855	66.2	56.6	9298	8368	164
				1140	67.3	76.7	11818	10636	154
				1710	69.4	118.7	16368	14731	138
				2565	72.1	185.0	23220	20898	126
				3420	74.4	254.6	29104	26194	114
Décor Class A Vero 29	BXRC-40A10K1-D-73	80	93	1050	35.4	37.2	5989	5390	161
				1400	36.2	50.6	7708	6937	152
				2100	37.6	79.0	10888	9799	138
				3150	39.5	124.4	15501	13951	125
				4200	41.2	172.9	19536	17583	113

Notes for Table 4:

1. Alternate drive currents in Table 4 are provided for reference only and are not a guarantee of performance.
2. Bridgelux maintains a $\pm 7\%$ tolerance on flux measurements.
3. Typical stabilized DC performance values are provided as reference only and are not a guarantee of performance.

Electrical Characteristics

Table 5: Electrical Characteristics

Part Number	Nominal Drive Current ¹ (mA)	Forward Voltage Pulsed, T _c = 25°C (V) ^{1,2,3,8}			Typical Coefficient of Forward Voltage ⁴ ΔV _f /ΔT _c (mV/°C)	Typical Thermal Resistance Junction to Case ^{5,6} R _{j-c} (C/W)	Driver Selection Voltages ⁷ (V)	
		Minimum	Typical	Maximum			V _f Min. Hot T _c = 105°C (V)	V _f Max. Cold ⁴ T _c = -40°C (V)
BXRC-xxx100x-B-7x	270	32.4	35.0	37.6	-16.1	0.49	31.1	38.7
	540	34.9	37.8	40.6	-16.1	0.57	33.6	41.6
BXRC-xxx100x-C-7x	360	32.4	35.0	37.6	-16.1	0.37	31.1	38.7
	720	34.9	37.7	40.5	-16.1	0.43	33.6	41.6
BXRC-xxx100x-D-7x	350	24.1	26.0	28.0	-11.8	0.49	23.1	28.7
	700	26.3	28.4	30.5	-11.8	0.57	25.3	31.3
BXRC-xxx200x-B-7x	450	32.4	35.0	37.6	-14.3	0.28	31.2	38.6
	900	34.7	37.5	40.3	-14.3	0.35	33.5	41.2
BXRC-xxx200x-C-7x	630	32.4	35.0	37.6	-14.3	0.20	31.2	38.6
	1260	34.9	37.8	40.6	-14.3	0.24	33.8	41.5
BXRC-xxx200x-D-7x	500	29.4	31.8	34.2	-13.3	0.34	28.4	35.0
	1000	31.8	34.4	37.0	-13.3	0.41	30.8	37.9
BXRC-xxx400x-B-7x	900	32.4	35.0	37.6	-14.9	0.15	31.2	38.6
	1800	35.2	38.0	40.9	-14.9	0.19	34.0	41.8
BXRC-xxx400x-C-7x	1170	32.4	35.0	37.6	-14.9	0.11	31.2	38.6
	2340	35.3	38.1	41.0	-14.9	0.13	34.1	42.0
BXRC-xxx400x-D-7x	1050	26.8	29.0	31.2	-12.2	0.16	25.8	32.0
	2100	29.2	31.5	33.9	-12.2	0.19	28.2	34.7
BXRC-xxx10Kx-B-7x	1800	48.1	52.0	55.9	-24.9	0.06	46.1	57.5
	3600	51.7	55.8	60.0	-24.9	0.07	49.7	61.6
BXRC-xxx10Kx-C-7x	1710	64.2	69.4	74.6	-33.2	0.04	61.5	76.8
	3420	68.8	74.4	80.0	-33.2	0.05	66.2	82.2
BXRC-xxx10Kx-D-7x	2100	34.8	37.6	40.4	-17.4	0.06	33.4	41.6
	4200	38.1	41.2	44.3	-17.4	0.07	36.7	45.4

Notes for Table 5:

- Parts are tested in pulsed conditions, T_c = 25°C. Pulse width is 10ms.
- Voltage minimum and maximum are provided for reference only and are not a guarantee of performance.
- Bridgelux maintains a tester tolerance of ± 0.10V on forward voltage measurements.
- Typical coefficient of forward voltage tolerance is ± 0.1mV for nominal current.
- Thermal resistance values are based from test data of a 3000K 80 CRI product.
- Thermal resistance value was calculated using total electrical input power; optical power was not subtracted from input power. The thermal interface material used during testing is not included in the thermal resistance value.
- V_f min hot and max cold values are provided as reference only and are not guaranteed by test. These values are provided to aid in driver design and selection over the operating range of the product.
- This product has been designed and manufactured per IEC 62031:2014. This product has passed dielectric withstand voltage testing at 1160 V. The working voltage designated for the insulation is 80V d.c. The maximum allowable voltage across the array must be determined in the end product application.

Eye Safety

Table 6: Eye Safety Risk Group (RG) Classifications

Part Number	Drive Current ³ (mA)	CCT ^{1,3}	
		2700K/3000K	4000K ²
BXRC-xxx100x-B-7x	270	RG1	RG1
	405	RG1	RG1
	540	RG1	RG1
BXRC-xxx100x-C-7x	360	RG1	RG1
	540	RG1	RG1
	720	RG1	RG2
BXRC-xxx100x-D-7x	350	RG1	RG1
	525	RG1	RG1
	700	RG1	RG1
BXRC-xxx200x-B-7x	450	RG1	RG1
	675	RG1	RG1
	900	RG1	RG1
BXRC-xxx200x-C-7x	630	RG1	RG1
	945	RG1	RG1
	1260	RG1	RG2
BXRC-xxx200x-D-7x	500	RG1	RG1
	750	RG1	RG1
	1000	RG1	RG1
BXRC-xxx400x-B-7x	900	RG1	RG1
	1350	RG1	RG1
	1800	RG1	RG1
BXRC-xxx400x-C-7x	1170	RG1	RG1
	1755	RG1	RG1
	2340	RG1	RG1
BXRC-xxx400x-D-7x	1050	RG1	RG1
	1575	RG1	RG1
	2100	RG1	RG1
BXRC-xxx10Kx-B-7x	1800	RG1	RG1
	2700	RG1	RG1
	3600	RG1	RG1
BXRC-xxx10Kx-C-7x	1710	RG1	RG1
	2565	RG1	RG1
	3420	RG1	RG2
BXRC-xxx10Kx-D-7x	2100	RG1	RG1
	3150	RG1	RG1
	4200	RG1	RG1

Notes for Table 6:

1. Eye safety classification for the use of Bridgelux Vero SE Series LED arrays is in accordance with specification IEC/TR 62778: Application of IEC 62471 for the assessment of blue light hazard to light sources and luminaires.
2. For products classified as RG2 at 4000K, $E_{thr} = 1847.5$ lx.

Absolute Maximum Ratings

Table 7: Maximum Ratings

Parameter	Maximum Rating		
LED Junction Temperature	125°C		
Storage Temperature	-40°C to +105°C		
Operating Case Temperature ¹	105°C		
Soldering Temperature ²	350°C or lower for a maximum of 10 seconds		
	BXRC-xxx100x-B-7x	BXRC-xxx100x-C-7x	BXRC-xxx100x-D-7x
Maximum Drive Current ³	540mA	720mA	700mA
Maximum Peak Pulsed Drive Current ⁴	770mA	1030mA	1000mA
Maximum Reverse Voltage ⁵	-60V	-60V	-45V

	BXRC-xxx200x-B-7x	BXRC-xxx200x-C-7x	BXRC-xxx200x-D-7x
Maximum Drive Current ³	900mA	1260mA	1000mA
Maximum Peak Pulsed Drive Current ⁴	1290mA	1800mA	1430mA
Maximum Reverse Voltage ⁵	-60V	-60V	-55V

	BXRC-xxx400x-B-7x	BXRC-xxx400x-C-7x	BXRC-xxx400x-D-7x
Maximum Drive Current ³	1800mA	2340mA	2100mA
Maximum Peak Pulsed Drive Current ⁴	2570mA	3340mA	3000mA
Maximum Reverse Voltage ⁵	-60V	-60V	-50V

	BXRC-xxx10Kx-B-7x	BXRC-xxx10Kx-C-7x	BXRC-xxx10Kx-D-7x
Maximum Drive Current ³	3600mA	3420mA	3960mA
Maximum Peak Pulsed Drive Current ^{4,6}	5140mA	4890mA	6000mA
Maximum Reverse Voltage ⁵	-90V	-120V	-65V

Notes for Table 7:

- For IEC 62717 requirement, please contact Bridgelux Sales Support.
- Refer to Bridgelux Application Note AN31, Handling and Assembly of Bridgelux Vero LED arrays, for more information.
- Arrays may be driven at higher currents however lumen maintenance may be reduced.
- Bridgelux recommends a maximum duty cycle of 10% and pulse width of 20ms when operating LED Arrays at the maximum peak pulsed current specified. Maximum peak pulsed current indicate values where the LED array can be driven without catastrophic failures.
- Light emitting diodes are not designed to be driven in reverse voltage and will not produce light under this condition. Maximum rating provided for reference only.
- Per IEC 62031, LED Modules for General Lighting - Safety Specifications, the maximum allowable current when using the Molex Pico Connector is 3150mA.

Performance Curves

Figure 1: Vero 10B Drive Current vs. Forward Voltage
($T_j=T_c=25^\circ\text{C}$)

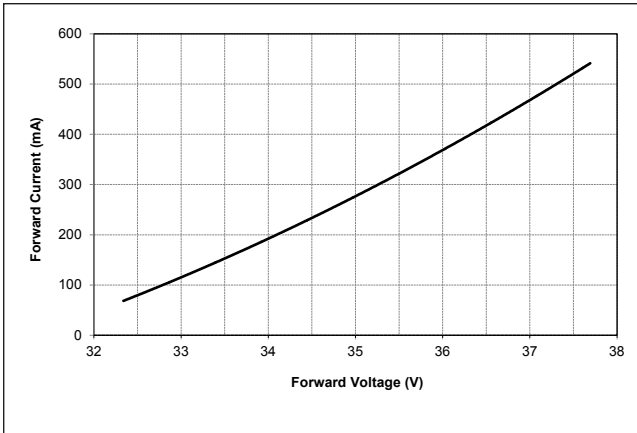

Figure 2: Vero 10C Drive Current vs. Forward Voltage
($T_j=T_c=25^\circ\text{C}$)

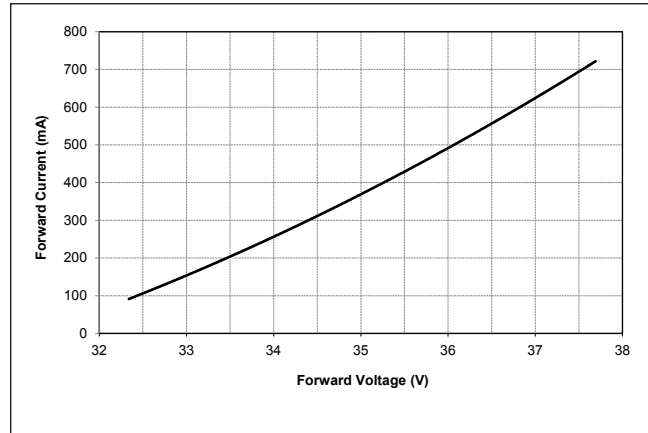

Figure 3: Vero 10D Drive Current vs. Forward Voltage
($T_j=T_c=25^\circ\text{C}$)

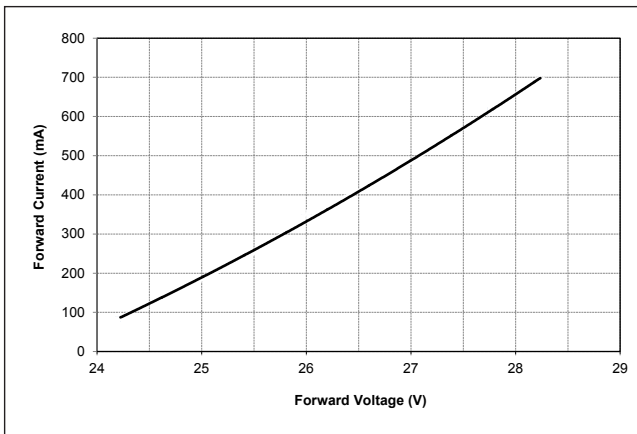

Figure 4: Vero 13B Drive Current vs. Forward Voltage
($T_j=T_c=25^\circ\text{C}$)

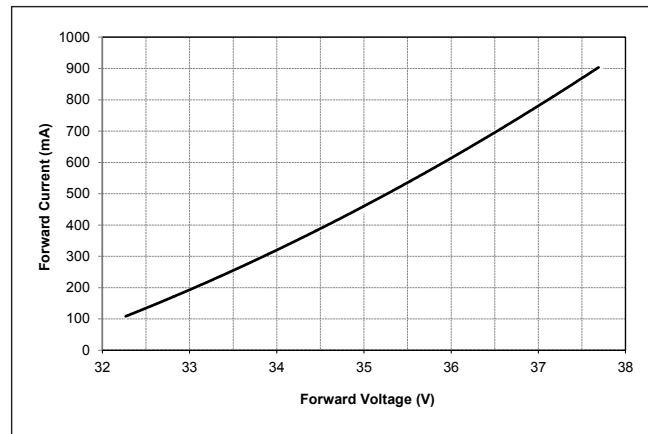

Figure 5: Vero 13C Drive Current vs. Forward Voltage
($T_j=T_c=25^\circ\text{C}$)

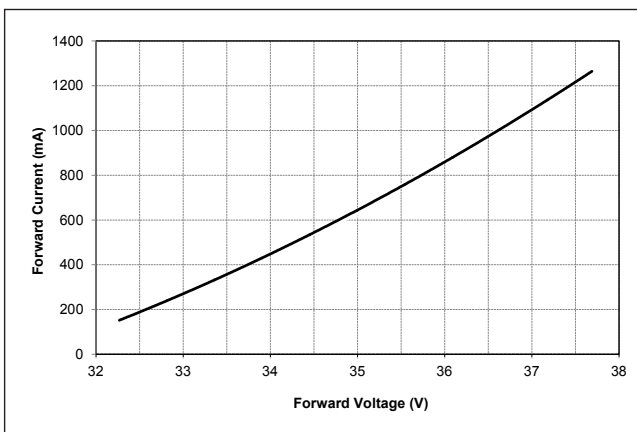
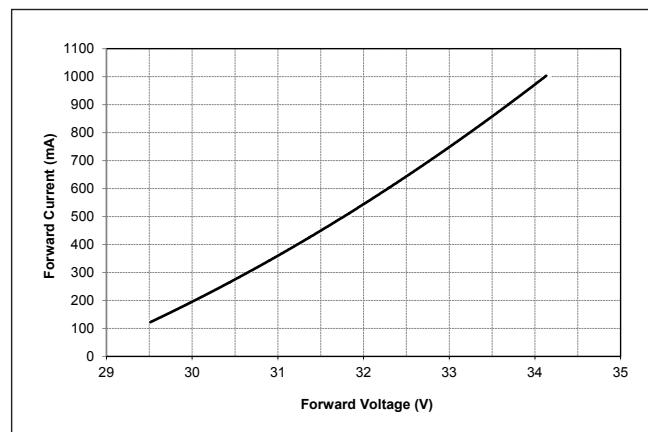

Figure 6: Vero 13D Drive Current vs. Forward Voltage
($T_j=T_c=25^\circ\text{C}$)



Performance Curves

Figure 7: Vero 18B Drive Current vs. Forward Voltage
($T_j=T_c=25^\circ\text{C}$)

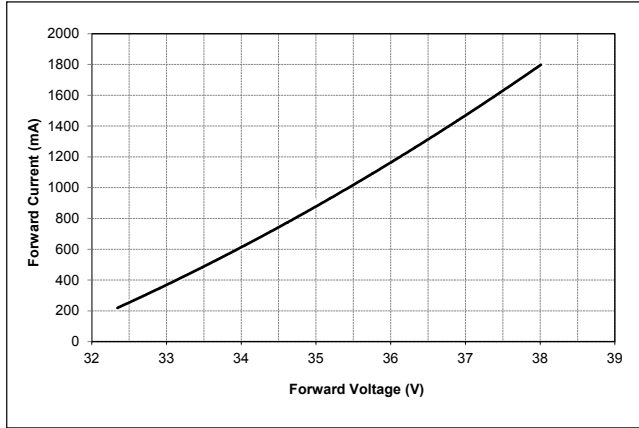

Figure 8: Vero 18C Drive Current vs. Forward Voltage
($T_j=T_c=25^\circ\text{C}$)

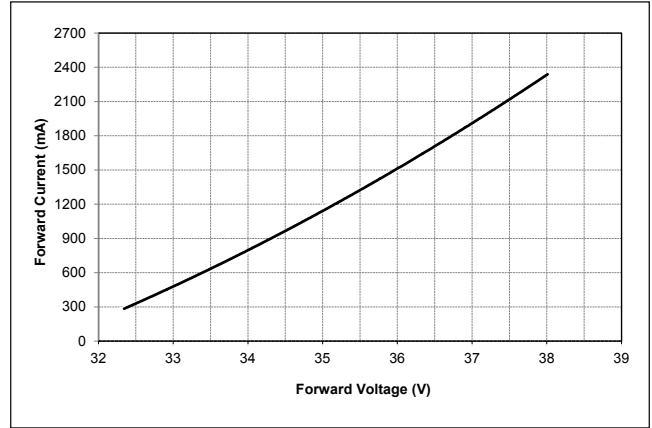

Figure 9: Vero 18D Drive Current vs. Forward Voltage
($T_j=T_c=25^\circ\text{C}$)

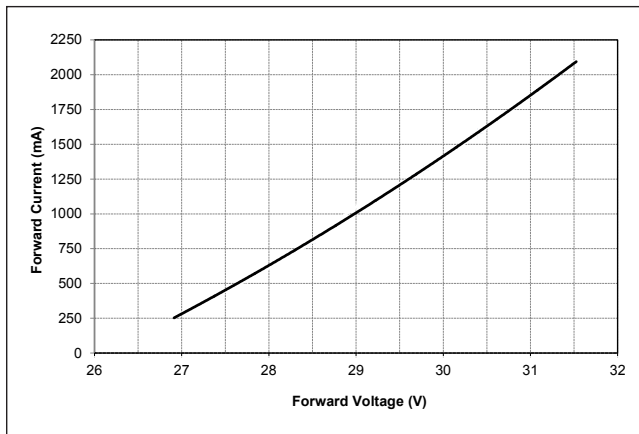

Figure 10: Vero 29B Drive Current vs. Forward Voltage
($T_j=T_c=25^\circ\text{C}$)

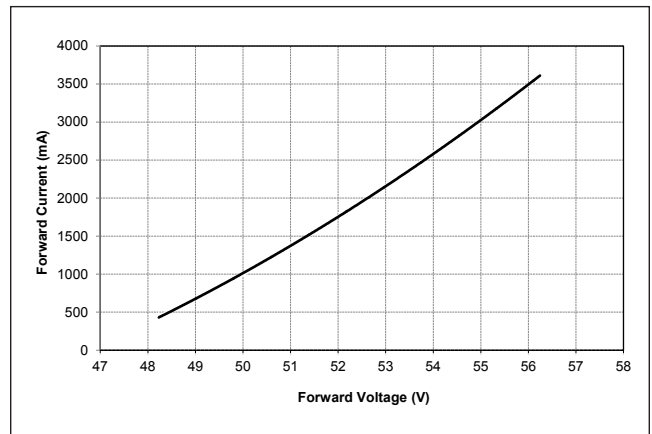

Figure 11: Vero 29C Drive Current vs. Forward Voltage
($T_j=T_c=25^\circ\text{C}$)

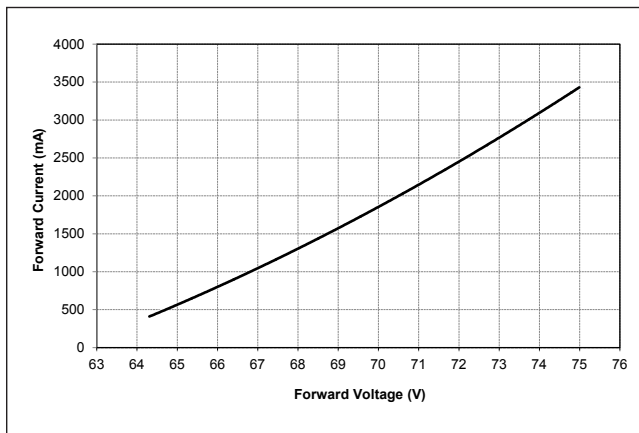
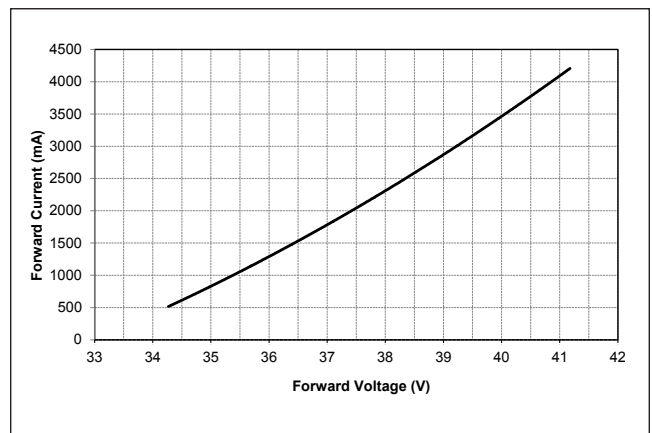

Figure 12: Vero 29D Drive Current vs. Forward Voltage
($T_j=T_c=25^\circ\text{C}$)



Performance Curves

Figure 13: Vero 10B Typical Relative Luminous Flux vs. Drive Current

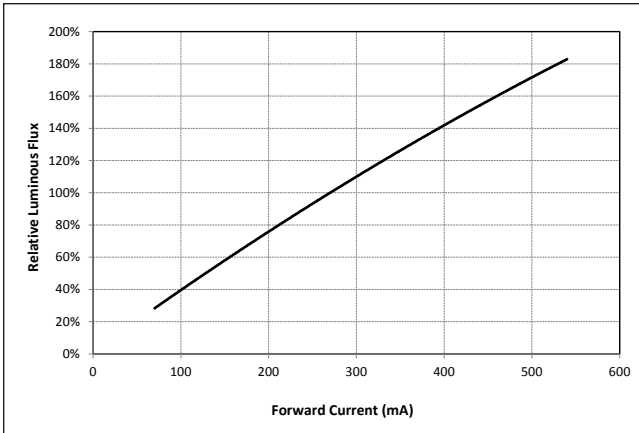

Figure 14: Vero 10C Typical Relative Luminous Flux vs. Drive Current

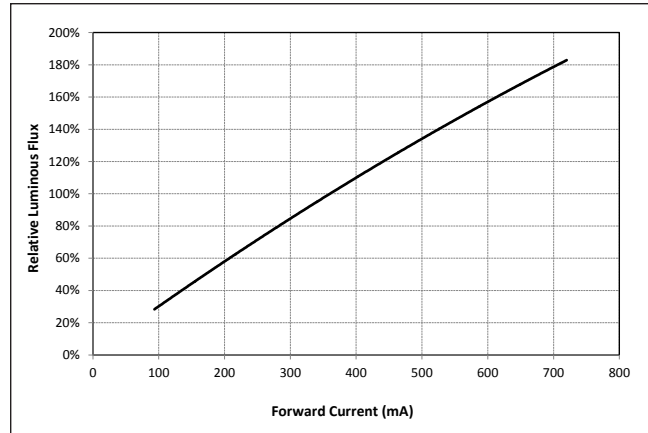

Figure 15: Vero 10D Typical Relative Luminous Flux vs. Drive Current

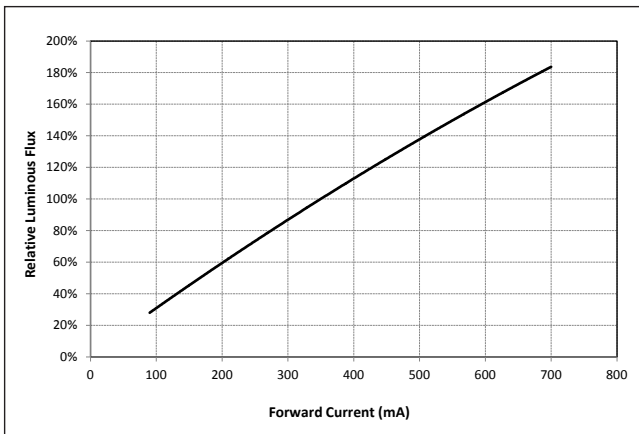

Figure 16: Vero 13B Typical Relative Luminous Flux vs. Drive Current

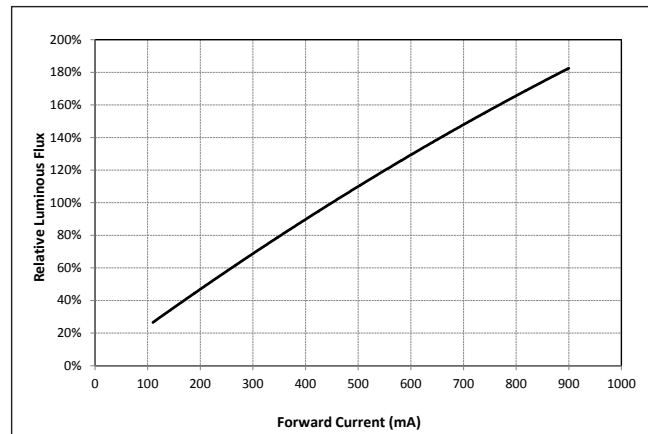

Figure 17: Vero 13C Typical Relative Luminous Flux vs. Drive Current

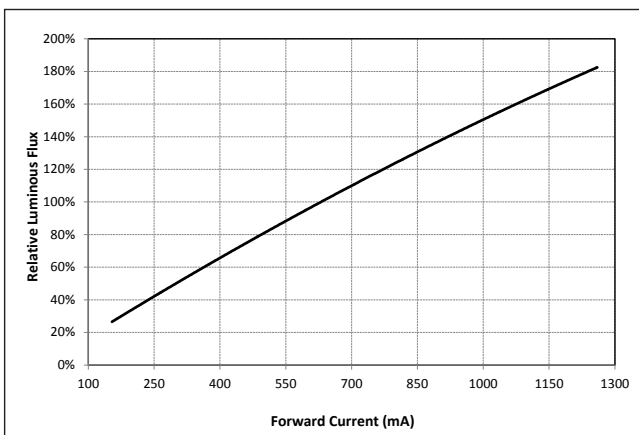
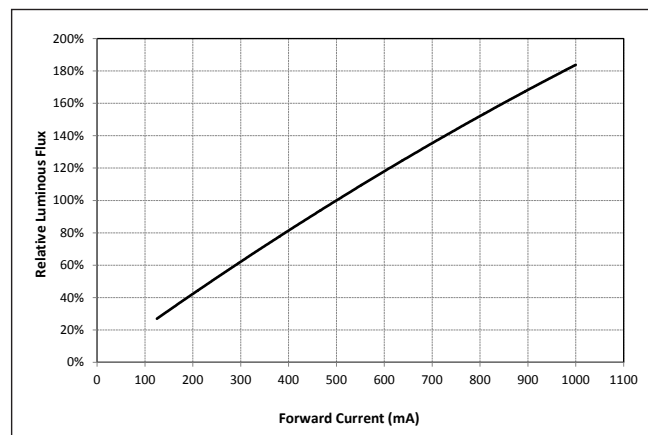

Figure 18: Vero 13D Typical Relative Luminous Flux vs. Drive Current



Performance Curves

Figure 19: Vero 18B Typical Relative Luminous Flux vs. Drive Current

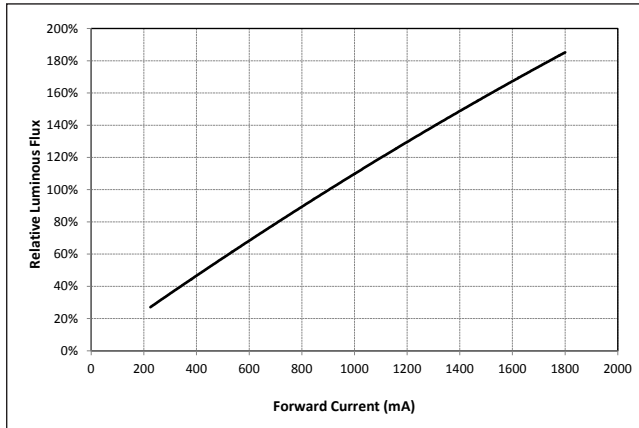

Figure 20: Vero 18C Typical Relative Luminous Flux vs. Drive Current

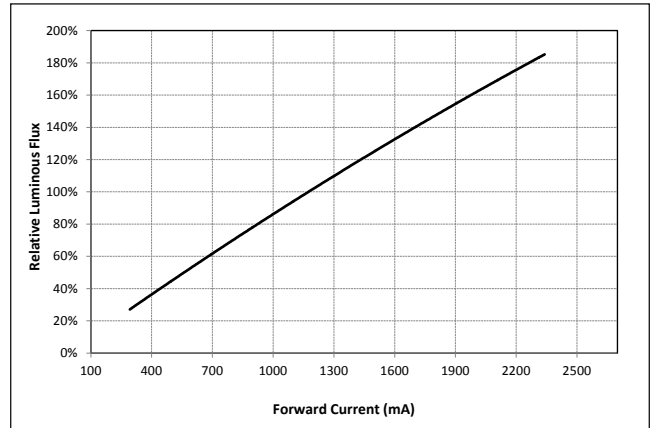

Figure 21: Vero 18D Typical Relative Luminous Flux vs. Drive Current

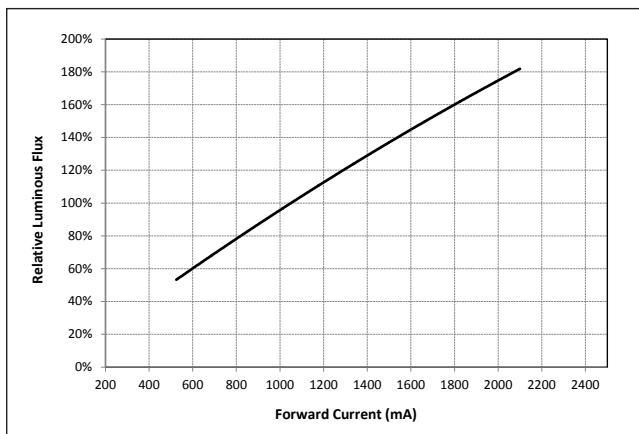

Figure 22: Vero 29B Typical Relative Luminous Flux vs. Drive Current

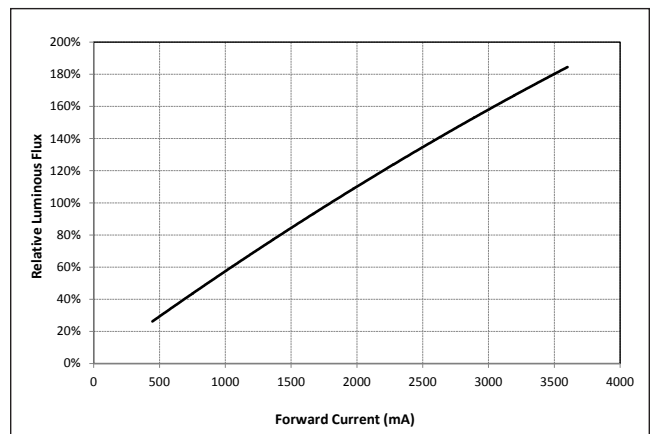

Figure 23: Vero 29C Typical Relative Luminous Flux vs. Drive Current

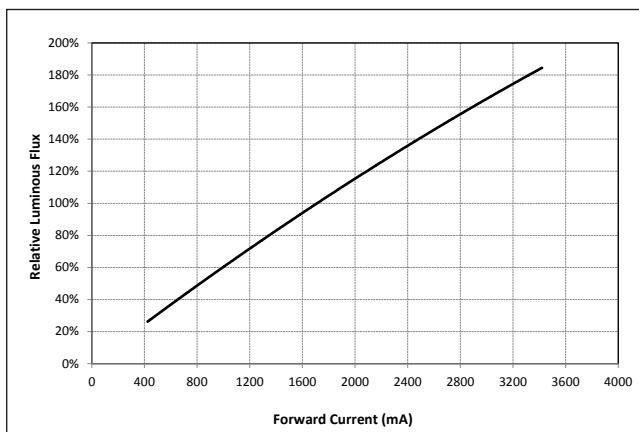
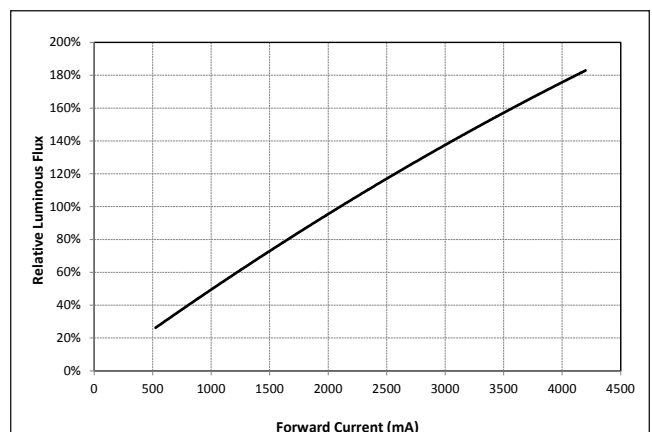

Figure 24: Vero 29C Typical Relative Luminous Flux vs. Drive Current



Performance Curves

Figure 25: Vero 10 Typical DC Flux vs. Case Temperature¹

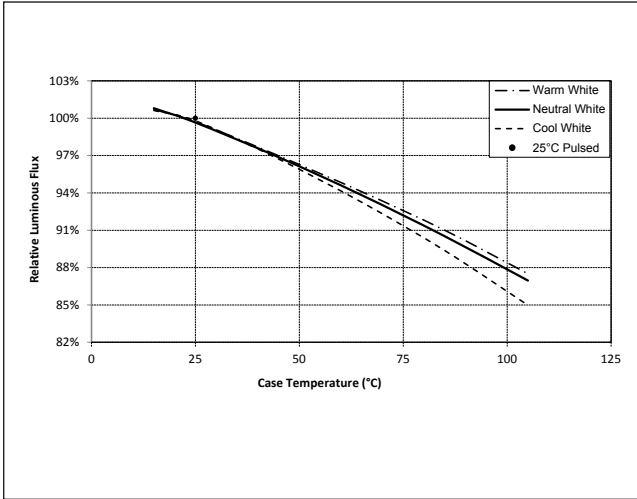

Figure 26: Vero 13 Typical DC Flux vs. Case Temperature¹

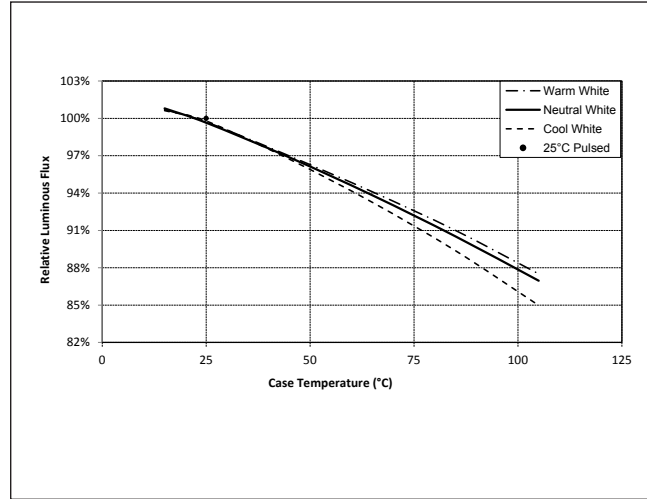

Figure 27: Vero 18 Typical DC Flux vs. Case Temperature¹

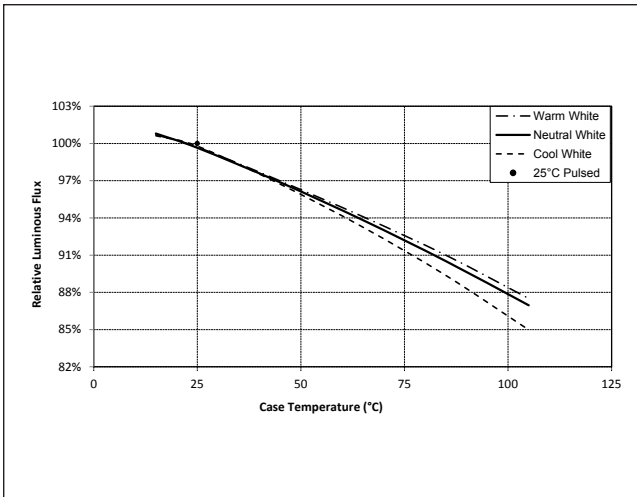
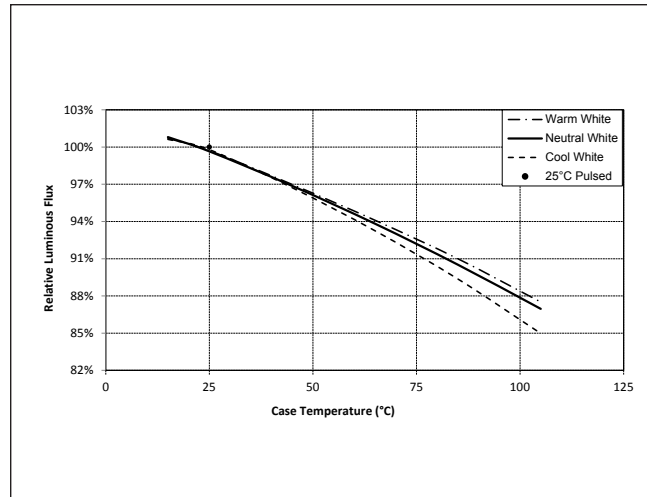

Figure 28: Vero 29 Typical DC Flux vs. Case Temperature¹



Note for Figures 25-28:

1. Flux measurements taken under DC conditions.
2. Characteristics shown for warm white based on 3000K and 80 CRI.
3. Characteristics shown for neutral white based on 4000K and 80 CRI.
4. Characteristics shown for cool white based on 5000K and 70 CRI.
5. For other color SKUs, the shift in color will vary. Please contact your Bridgelux Sales Representative for more information.

Performance Curves

Figure 29: 3000K Class A Color Shift vs. Case Temperature¹

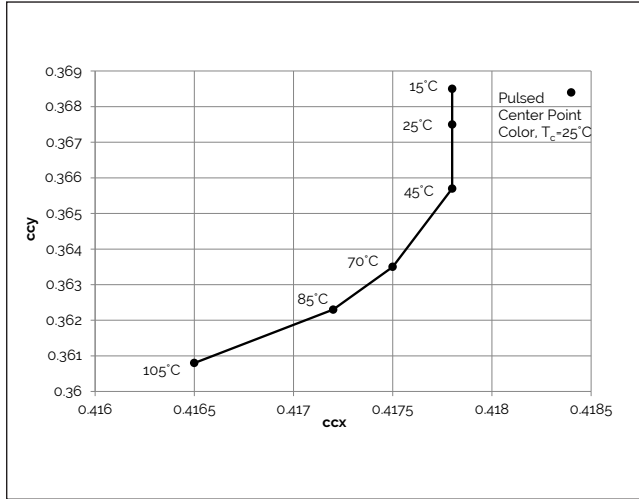

Figure 30: 3500K Class A Color Shift vs. Case Temperature¹

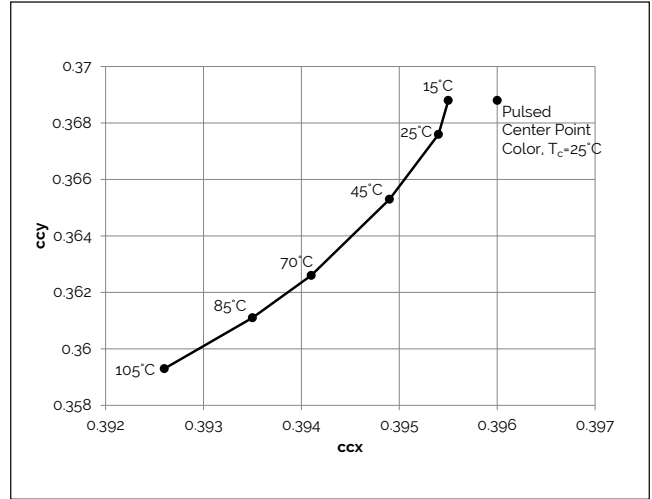
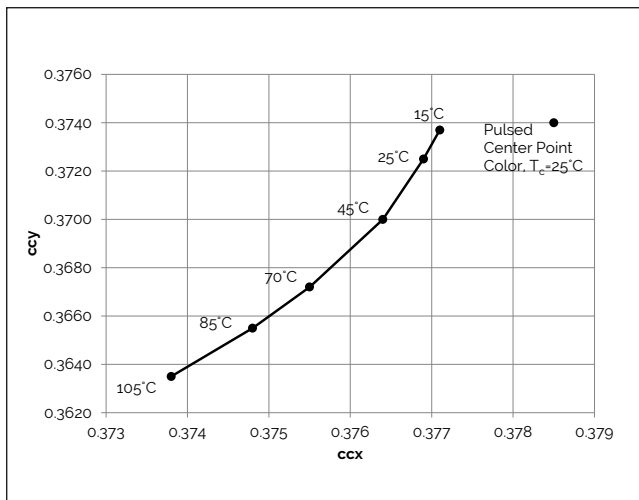

Figure 31: 4000K Class A Color Shift vs. Case Temperature¹



Note for Figures 29-31:

1. Measurements made under DC test conditions at the nominal drive current.
2. Typical color shift is shown with a tolerance of ± 0.002 .

Typical Radiation Pattern

Figure 32: Typical Spatial Radiation Pattern

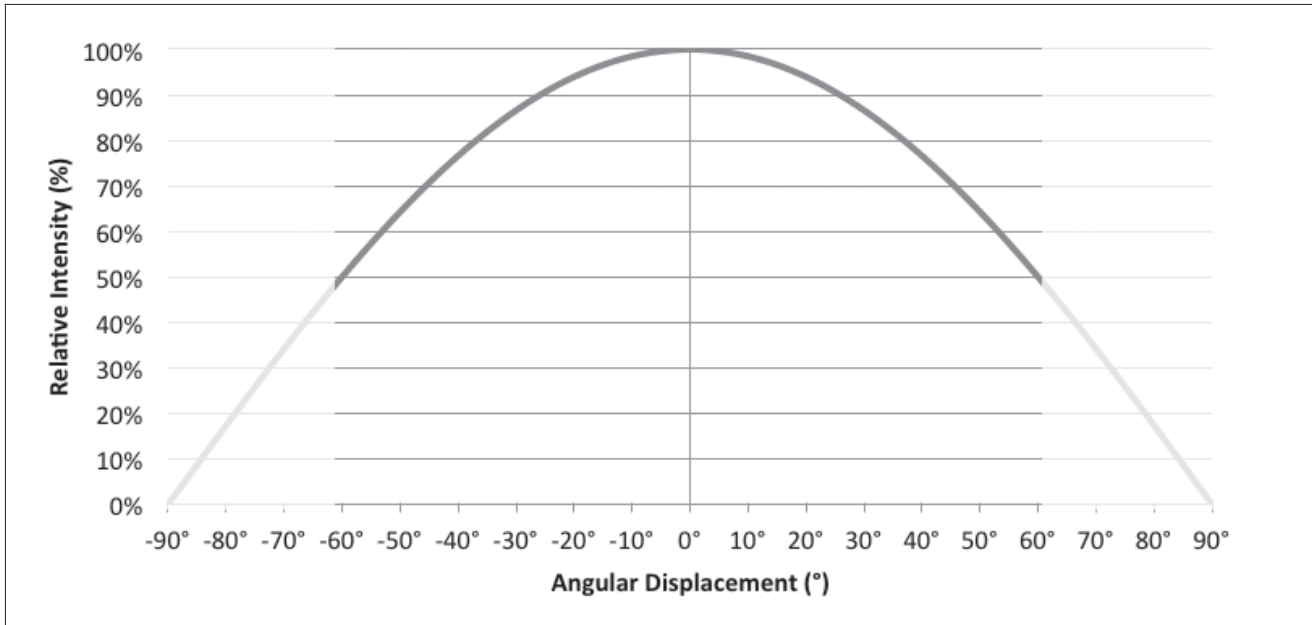

Notes for Figure 32:

1. Typical viewing angle is 120°.
2. The viewing angle is defined as the off axis angle from the centerline where I_v is $\frac{1}{2}$ of the peak value.

Figure 33: Typical Polar Radiation Pattern

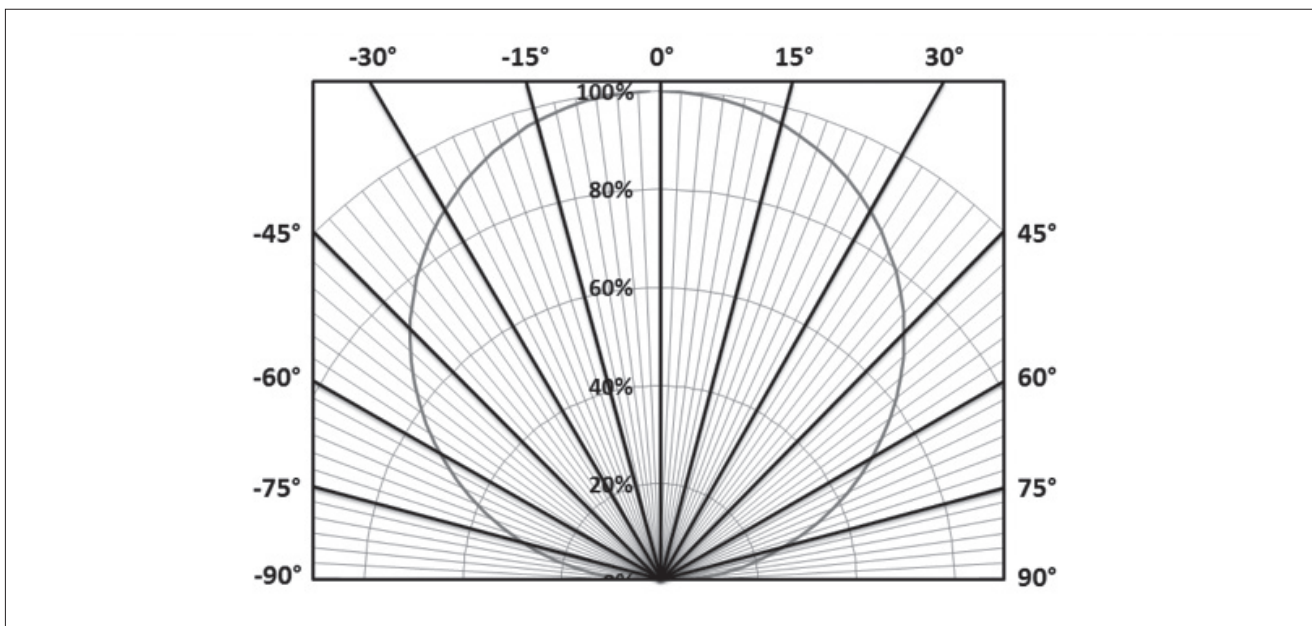

Mechanical Dimensions

Figure 34: Drawing for Vero 10 LED Array

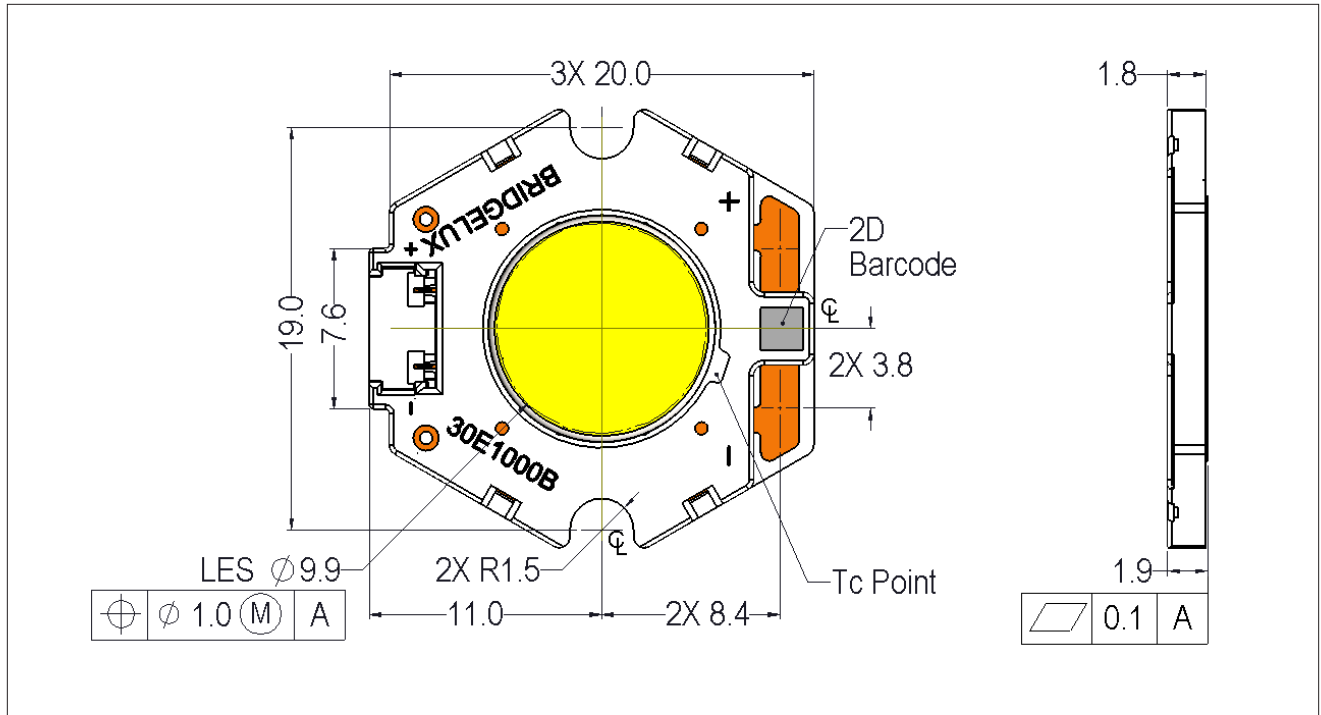

Notes for Figure 34:

1. Drawings are not to scale.
2. Drawing dimensions are in millimeters.
3. Unless otherwise specified, tolerances are $\pm 0.01\text{mm}$.
4. Mounting slots (2X) are for M2.5 screws.
5. Bridgelux recommends two tapped holes for mounting screws with $19.0 \pm 0.10\text{mm}$ center-to-center spacing.
6. Screws with flat shoulders (pan, dome, button, round, truss, mushroom) provide optimal torque control. Do NOT use flat, countersink, or raised head screws.
7. Solder pads and connector port are labeled "+" and "-" to denote positive and negative, respectively.
8. It is not necessary to provide electrical connections to both the solder pads and the connector port. Either set may be used depending on application specific design requirements.
9. Refer to Application Notes AN30 and AN31 for product handling, mounting and heat sink recommendations.
10. The optical center of the LED Array is nominally defined by the mechanical center of the array to a tolerance of $\pm 0.2\text{mm}$.
11. Bridgelux maintains a flatness of 0.10mm across the mounting surface of the array.

Mechanical Dimensions

Figure 35: Drawing for Vero 13 LED Array

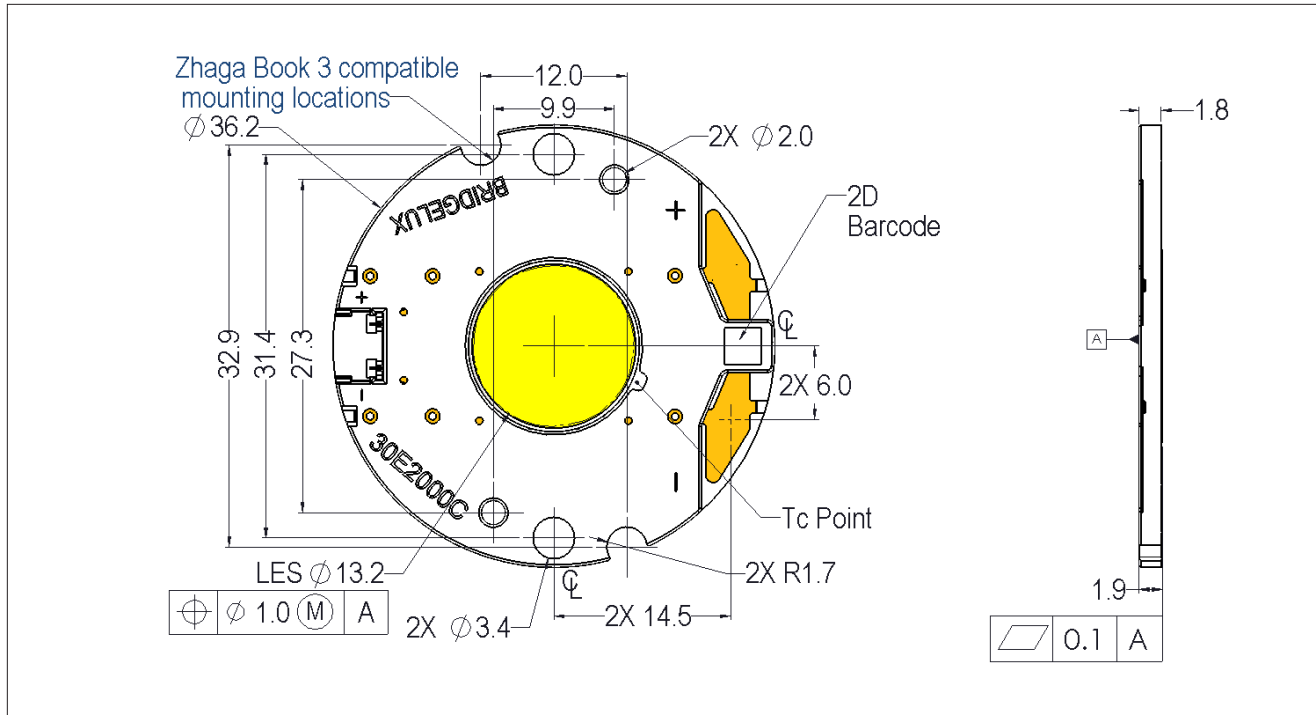

Notes for Figure 35:

1. Drawings are not to scale.
2. Drawing dimensions are in millimeters.
3. Unless otherwise specified, tolerances are $\pm 0.01\text{mm}$.
4. Mounting holes (2X) are for M2.5 screws.
5. Bridgelux recommends two tapped holes for mounting screws with $31.4 \pm 0.10\text{mm}$ center-to-center spacing.
6. Screws with flat shoulders (pan, dome, button, round, truss, mushroom) provide optimal torque control. Do NOT use flat, countersink, or raised head screws.
7. Solder pads and connector port are labeled "+" and "-" to denote positive and negative, respectively.
8. It is not necessary to provide electrical connections to both the solder pads and the connector port. Either set may be used depending on application specific design requirements.
9. Refer to Application Notes AN30 and AN31 for product handling, mounting and heat sink recommendations.
10. The optical center of the LED Array is nominally defined by the mechanical center of the array to a tolerance of $\pm 0.2\text{mm}$.
11. Bridgelux maintains a flatness of 0.10mm across the mounting surface of the array.

Mechanical Dimensions

Figure 36: Drawing for Vero 18 LED Array

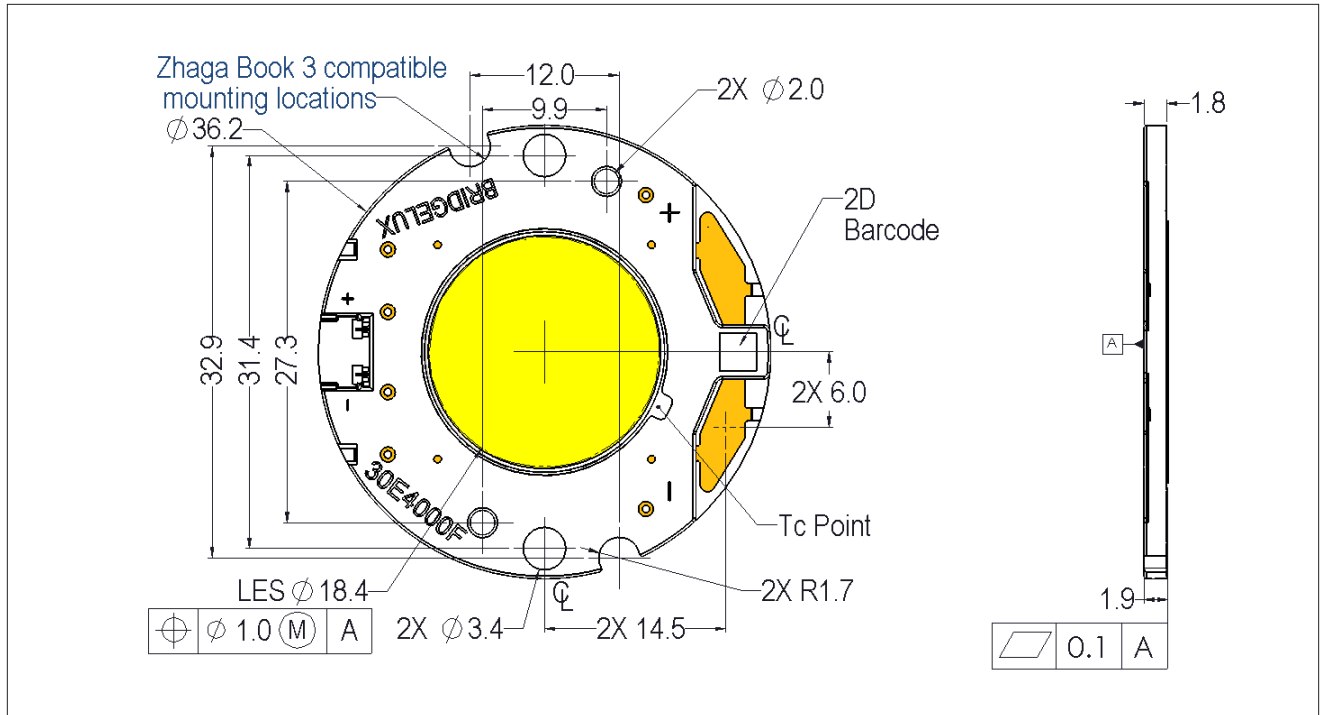

Notes for Figure 36:

1. Drawings are not to scale.
2. Drawing dimensions are in millimeters.
3. Unless otherwise specified, tolerances are $\pm 0.01\text{mm}$.
4. Mounting holes (2X) are for M2.5 screws.
5. Bridgelux recommends two tapped holes for mounting screws with $31.4 \pm 0.10\text{mm}$ center-to-center spacing.
6. Screws with flat shoulders (pan, dome, button, round, truss, mushroom) provide optimal torque control. Do NOT use flat, countersink, or raised head screws.
7. Solder pads and connector port are labeled "+" and "-" to denote positive and negative, respectively.
8. It is not necessary to provide electrical connections to both the solder pads and the connector port. Either set may be used depending on application specific design requirements.
9. Refer to Application Notes AN30 and AN31 for product handling, mounting and heat sink recommendations.
10. The optical center of the LED Array is nominally defined by the mechanical center of the array to a tolerance of $\pm 0.2\text{mm}$.
11. Bridgelux maintains a flatness of 0.10mm across the mounting surface of the array.

Mechanical Dimensions

Figure 37: Drawing for Vero 29 LED Array

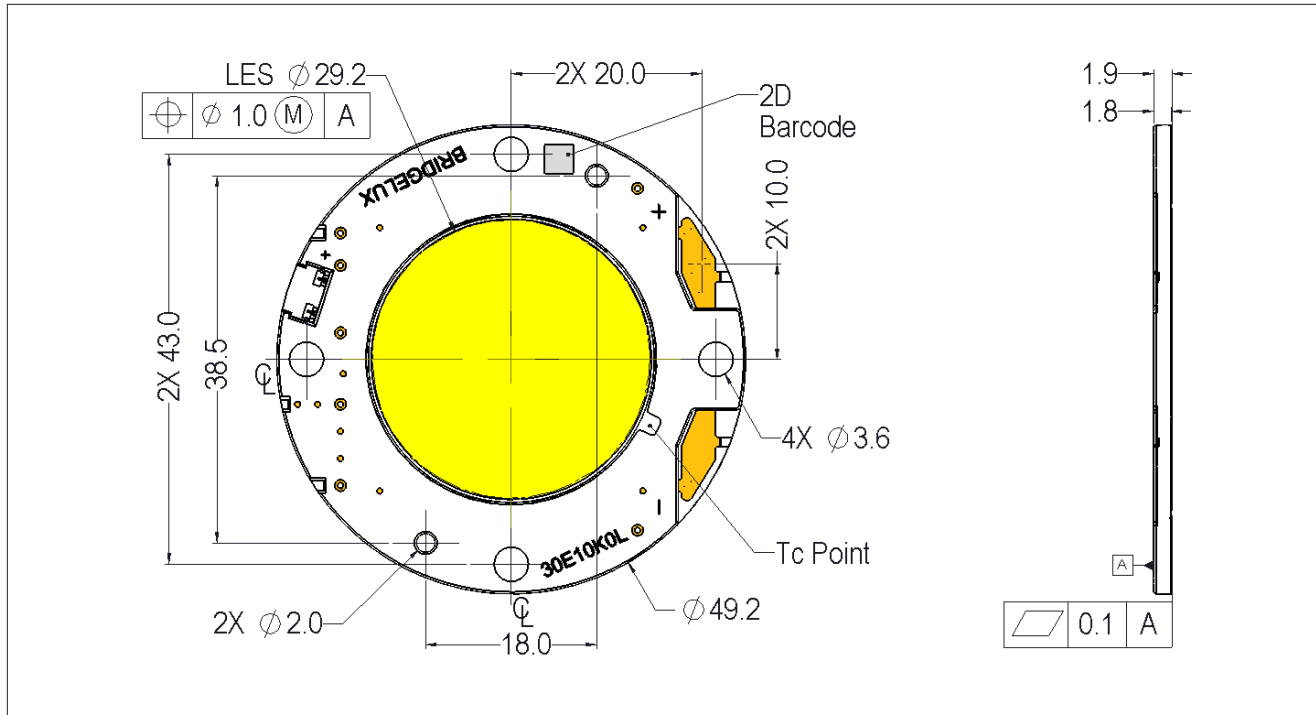

Notes for Figure 37:

1. Drawings are not to scale.
2. Drawing dimensions are in millimeters.
3. Unless otherwise specified, tolerances are $\pm 0.01\text{mm}$.
4. Mounting holes (2X) are for M3 screws.
5. Bridgelux recommends two tapped holes for mounting screws with $43.0 \pm 0.10\text{mm}$ center-to-center spacing.
6. Screws with flat shoulders (pan, dome, button, round, truss, mushroom) provide optimal torque control. Do NOT use flat, countersink, or raised head screws.
7. Solder pads and connector port are labeled "+" and "-" to denote positive and negative, respectively.
8. It is not necessary to provide electrical connections to both the solder pads and the connector port. Either set may be used depending on application specific design requirements.
9. Refer to Application Notes AN30 and AN31 for product handling, mounting and heat sink recommendations.
10. The optical center of the LED Array is nominally defined by the mechanical center of the array to a tolerance of $\pm 0.2\text{mm}$.
11. Bridgelux maintains a flatness of 0.10mm across the mounting surface of the array.

Packaging and Labeling

Figure 38: Drawing for Vero 10 Packaging Tray

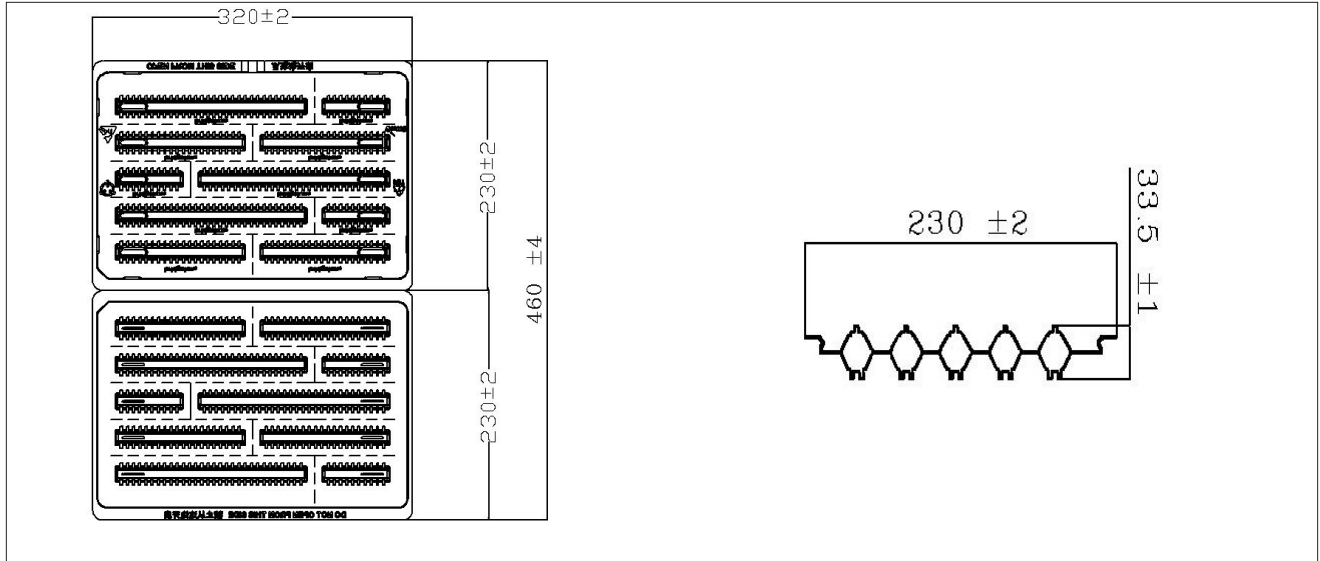

Notes for Figure 38:

1. Dimensions are in millimeters.
2. Drawing is not to scale.

Figure 39: Drawing for Vero 13 Packaging Tray

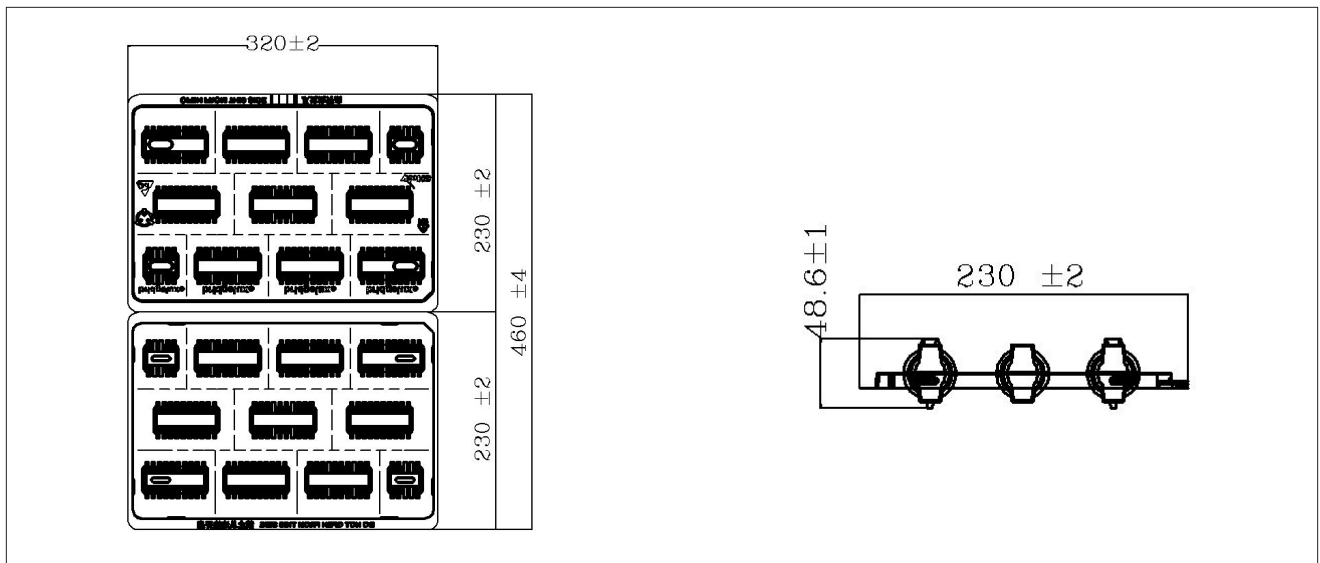

Notes for Figure 39:

1. Dimensions are in millimeters.
2. Drawing is not to scale.

Packaging Labeling

Figure 40: Drawing for Vero 18 Packaging Tray

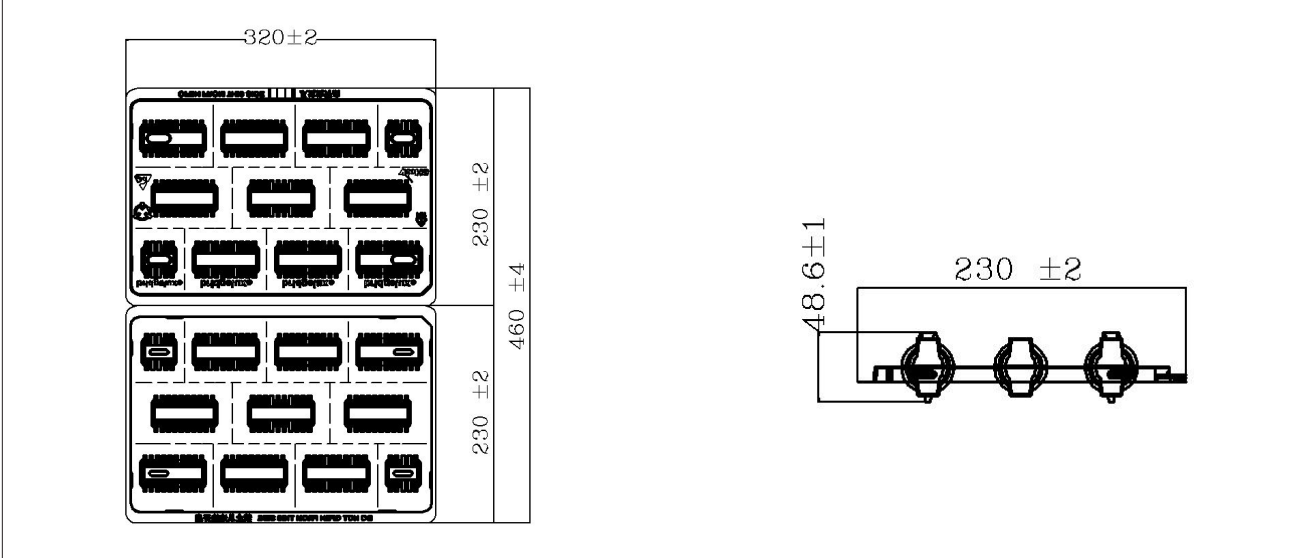

- Notes for Figure 40:
1. Dimensions are in millimeters.
 2. Drawing is not to scale.

Figure 41: Drawing for Vero 29 Packaging Tray

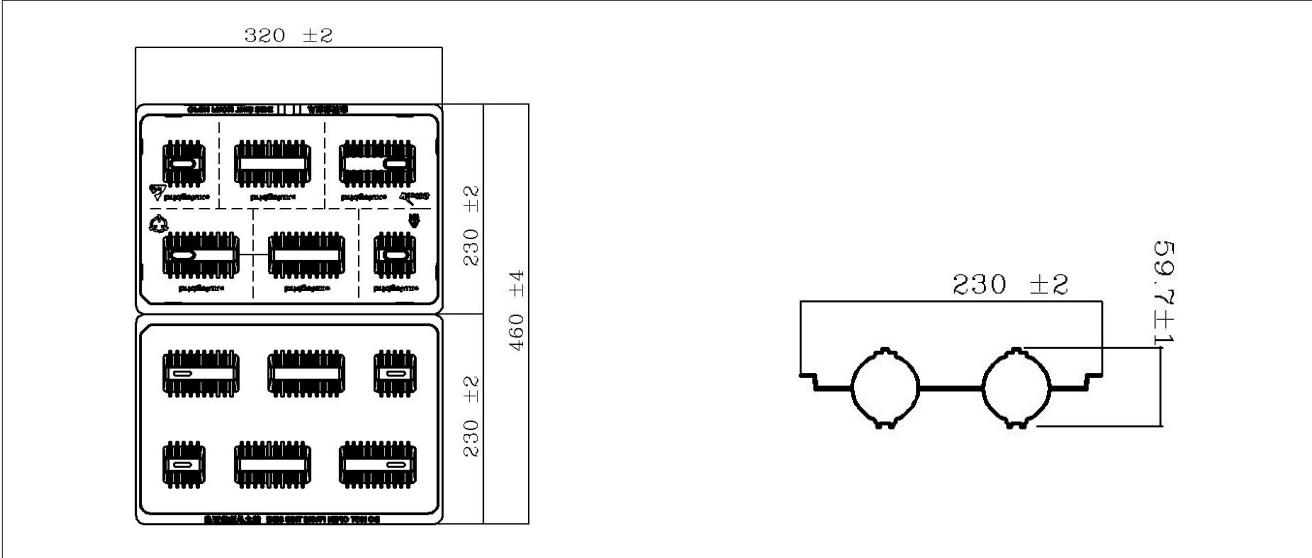

- Notes for Figure 41:
1. Dimensions are in millimeters.
 2. Drawing is not to scale.

Packaging and Labeling

Figure 42: Vero Series Packaging and Labeling

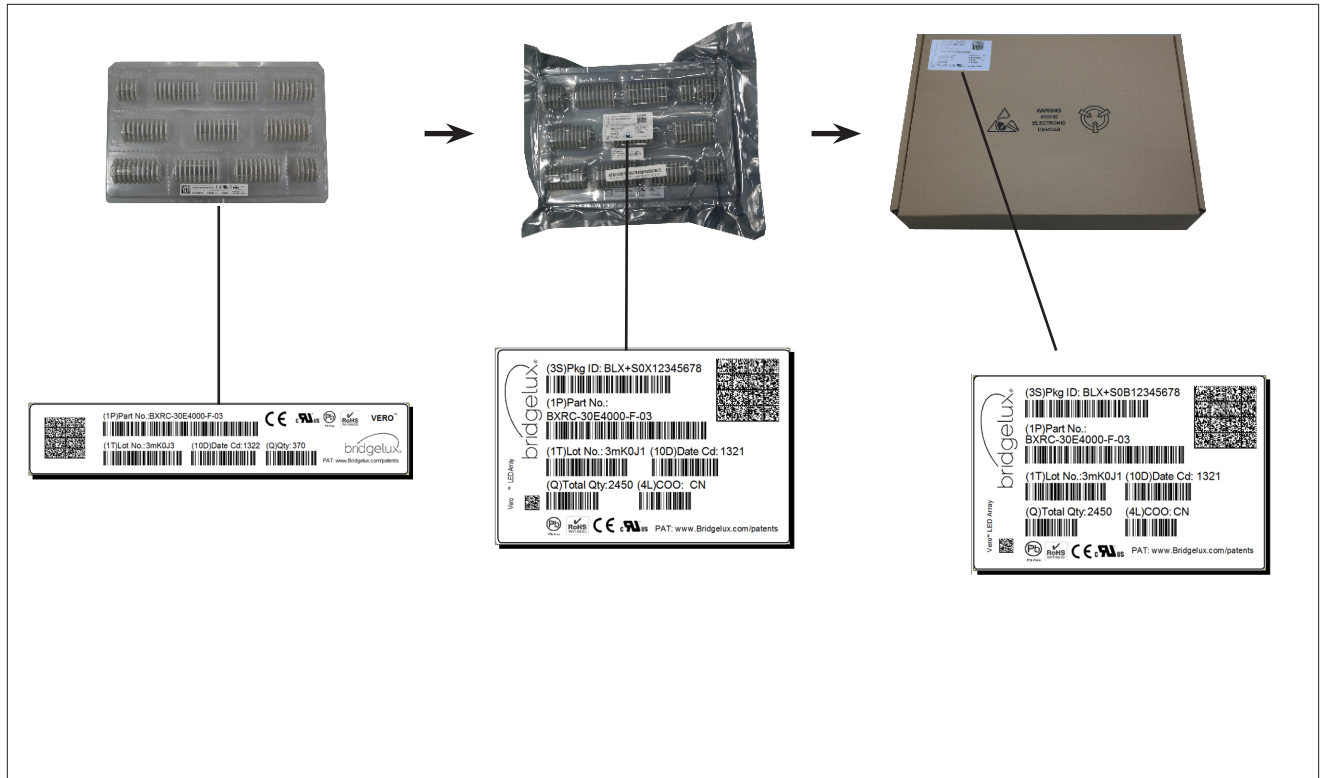

Notes for Figure 42:

1. Each tray holds for Vero 10: 200 COBs, Vero 13: 100 COBs, Vero 18: 100 COBs, Vero 29: 50 COBs.
2. Each tray is vacuum sealed in an anti-static bag and placed in its own box.
3. Each tray, bag and box is to be labeled as shown above.

Figure 43: Product Labeling

Bridgelux COB arrays have laser markings on the back side of the substrate to help with product identification. In addition to the product identification markings, Bridgelux COB arrays also contain markings for internal Bridgelux manufacturing use only. The image below shows which markings are for customer use and which ones are for Bridgelux internal use only. The Bridgelux internal manufacturing markings are subject to change without notice, however these will not impact the form, function or performance of the COB array.



Design Resources

Application Notes

Bridgelux has developed a comprehensive set of application notes and design resources to assist customers in successfully designing with the Vero product family of LED array products. For all available application notes visit www.bridgelux.com.

Optical Source Models

Optical source models and ray set files are available for all Bridgelux products. For a list of available formats, visit www.bridgelux.com.

3D CAD Models

Three dimensional CAD models depicting the product outline of all Bridgelux Vero LED arrays are available in both IGS and STEP formats. Please contact your Bridgelux sales representative for assistance.

LM80

LM80 testing is on going. Please contact your Bridgelux sales representative for more information.

Precautions

CAUTION: CHEMICAL EXPOSURE HAZARD

Exposure to some chemicals commonly used in luminaire manufacturing and assembly can cause damage to the LED array. Please consult Bridgelux Application Note AN31 for additional information.

CAUTION: RISK OF BURN

Do not touch the Vero LED array during operation. Allow the array to cool for a sufficient period of time before handling. The Vero LED array may reach elevated temperatures such that could burn skin when touched.

CAUTION

CONTACT WITH LIGHT EMITTING SURFACE (LES)

Avoid any contact with the LES. Do not touch the LES of the LED array or apply stress to the LES (yellow phosphor resin area). Contact may cause damage to the LED array.

Optics and reflectors must not be mounted in contact with the LES (yellow phosphor resin area). Optical devices may be mounted on the top surface of the plastic housing of the Vero LED array. Use the mechanical features of the LED array housing, edges and/or mounting holes to locate and secure optical devices as needed.

Disclaimers

MINOR PRODUCT CHANGE POLICY

The rigorous qualification testing on products offered by Bridgelux provides performance assurance. Slight cosmetic changes that do not affect form, fit, or function may occur as Bridgelux continues product optimization.

STANDARD TEST CONDITIONS

Unless otherwise stated, array testing is performed at the nominal drive current.

About Bridgelux: We Build Light That Transforms

At Bridgelux, we help companies, industries and people experience the power and possibility of light. Since 2002, we've designed LED solutions that are high performing, energy efficient, cost effective and easy to integrate. Our focus is on light's impact on human behavior, delivering products that create better environments, experiences and returns—both experiential and financial. And our patented technology drives new platforms for commercial and industrial luminaires.

For more information about the company, please visit
bridgelux.com
twitter.com/Bridgelux
facebook.com/Bridgelux
linkedin.com/company/Bridgelux-inc-_2
WeChat ID: BridgeluxInChina



101 Portola Avenue
Livermore, CA 94551
Tel (925) 583-8400
www.bridgelux.com

© 2016 Bridgelux, Inc. All rights reserved 2016. Product specifications are subject to change without notice. Bridgelux, the Bridgelux stylized logo design and Vero are registered trademarks, and Decor Series is a trademark of Bridgelux, Inc. All other trademarks are the property of their respective owners.

Bridgelux Gen. 7 Décor Series Class A Product Data Sheet DS95 Rev C (11/2016)